



INSTALLATION GUIDE*

The **OSB.Comfort™** boards manufactured by Styro Rail™ are composed of type 2 expanded polystyrene [EPS] rigid insulation laminated to an oriented structural board [OSB]. They comprise of perforations for complying with permeability requirements.

➤ RECOMMENDED USE

Install **OSB.Comfort™** boards on the exterior surface of framed walls in order to obtain a continuous thermal envelope, reinforcement against diagonal deformations and to offer support for the fastening of masonry ties or wooden furs for lightweight siding.

➤ PANEL COMPOSITION

A Type 2 Expanded Polystyrene Rigid Panel Insulation [EPS] manufactured by Styro Rail™

B 11 mm [7/16"] oriented structural board

C Printed lines at 406 mm [16"] and at 610 mm [24"] to facilitate the identification of the studs located behind the panels

D Printed line at 1219 mm [48"]

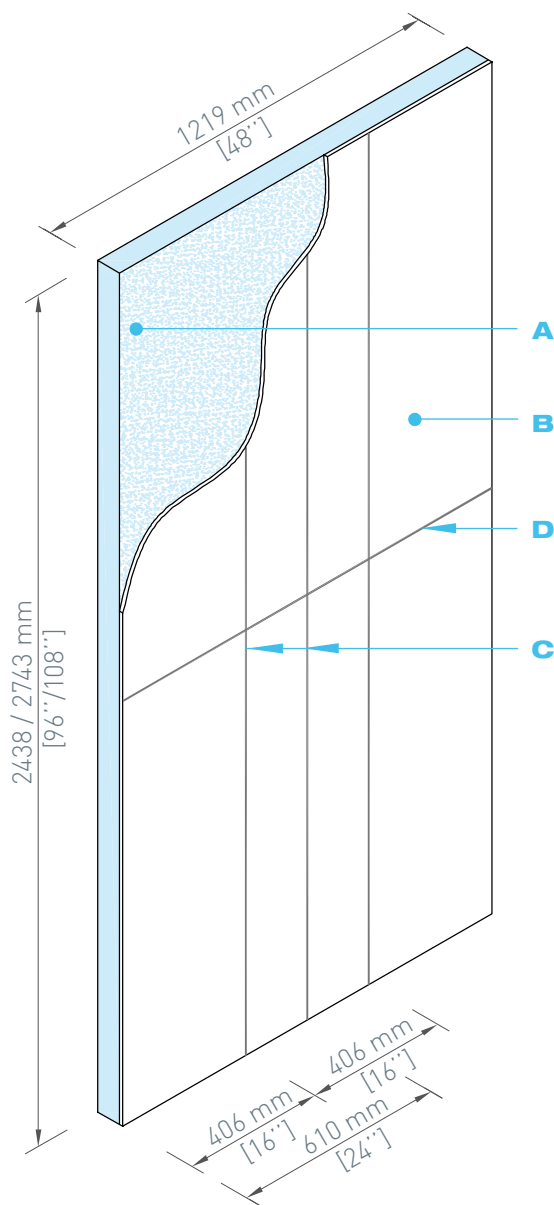

* Use the fixation method described in this guide for Part 9, Code de construction du Québec 2010 [CCQ] buildings; buildings of maximum 3 stories, maximum 600 m² and used for the following purposes: housing, commercial establishments, business establishments or low and medium-risk industrial establishments. Other buildings must follow the CCQ Part 3 and must have plans and specifications. Use the described fixation method in this guide for Part 9 buildings located in municipalities where low to moderate wind conditions occur. The buildings located in municipalities where high wind conditions occur, must comply to CCQ Part 4 and to municipality standards. The Appendix C of the National Building Code of Canada [NBC] quote few municipalities with high risk in Quebec: La Pocatière, Baie St-Paul, La Malbaie, Montmagny and Rivière-du-Loup.

PANEL INSTALLATION

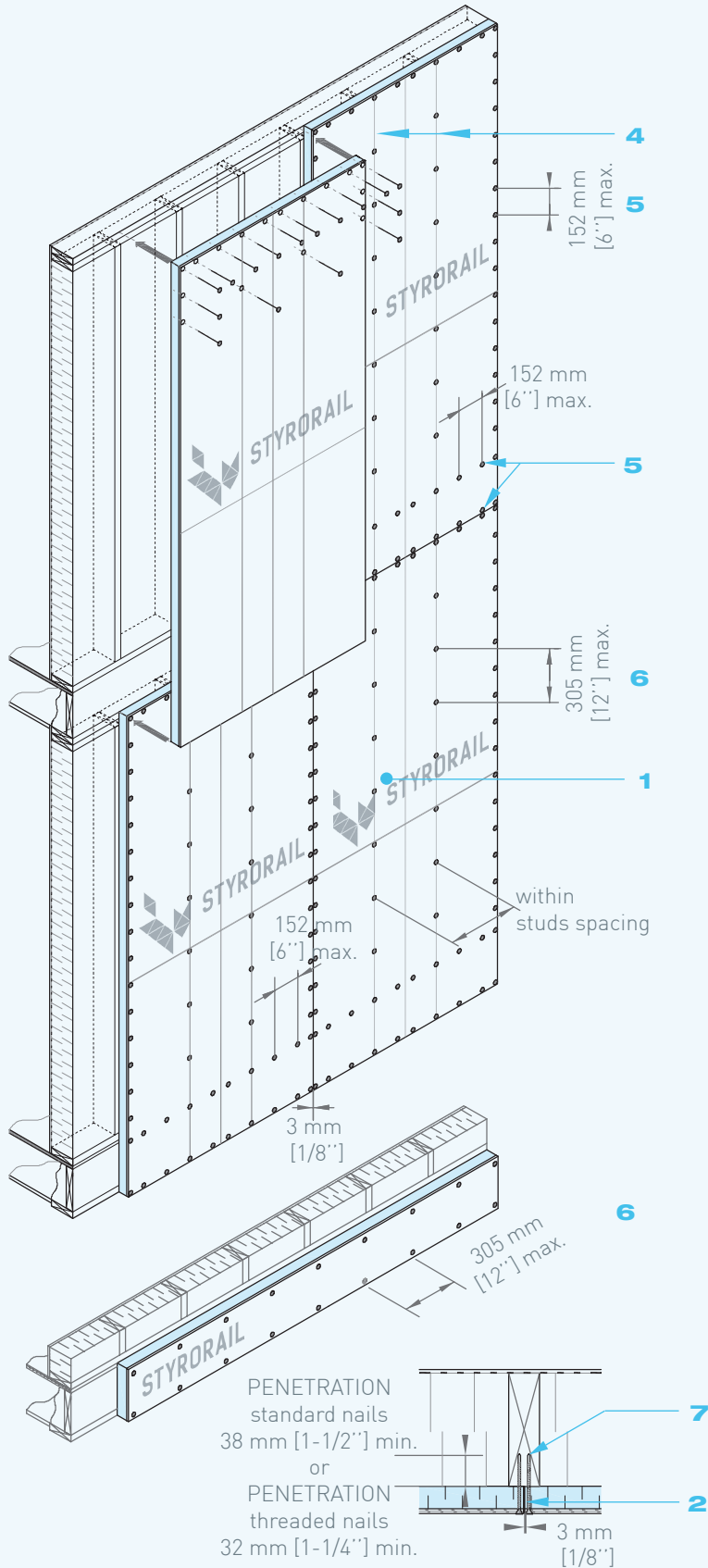

OSB.COMFORT™

© STYRO RAIL™ | 2017-01

GENERAL FIXATION

- 1** Install panels, from bottom up, the OSB panel located on the exterior side. Install panels consistently and continually.
- 2** Leave a spacing of 3 mm [1/8"] at the panels edges.
- 3** The panels can be installed vertically or horizontally.
- 4** If the panels are installed vertically; coincide printed lines with studs located behind the panels to facilitate the identification of the studs located behind the panels.
- 5** Nail the panels by allowing a spacing of maximum 152 mm [6"] at the ends and supported edges.
- 6** Nail the panels by allowing a spacing of maximum 305 mm [12"] at intermediate studs and on edges of the strip towards the joist header.
- 7** Use 8d standard nails or threaded nails ensuring a penetration of minimum 38 mm [1-1/2"] or use 8d ring-shank ensuring a penetration of minimum 32 mm [1-1/4"] in the studs.

PANEL INSTALLATION

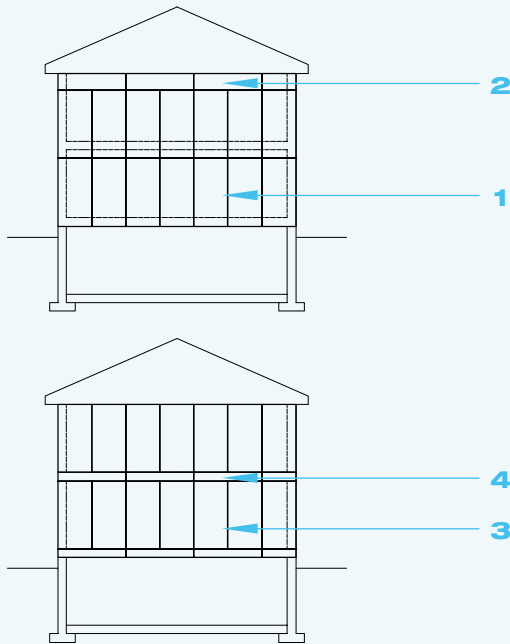

WEATHERPROOFING PANELS

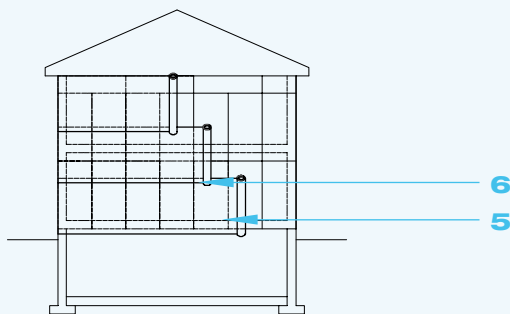

CLADDING INSTALLATION

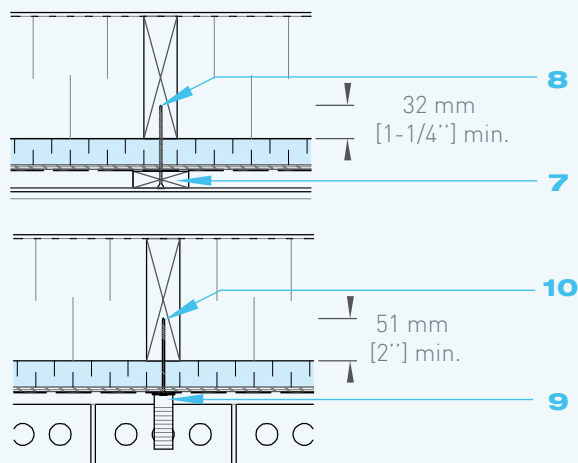

OSB.COMFORT™

© STYRO RAIL™ | 2017-01

➤ INSTALLATION [RENOVATION]

- 1** Install the panels on the framed wall; from the bottom up.
- 2** If covered height does not allow full-size panel installation, cut strips of panels accordingly to necessary dimensions to fill the upper space of the wall. Fix strips as per the installation method described in this guide.

➤ INSTALLATION [NEW CONSTRUCTION]

- 3** Install the panels on the framed wall; before the erection.
- 4** Cut the panels in strips as per the necessary dimensions toward the joist header. Fix strips as per the installation method described in this guide.

➤ AIR / WEATHER BARRIER

- 5** Install an air barrier in a roll format over the entire panel's surface as per the recommendations of the manufacturer and as per the plans and specifications. Install from the bottom up.
- 6** Seal all horizontal and vertical joints with a sealing tape compatible with the membrane.

➤ LIGHTWEIGHT SIDING

- 7** On the air barrier; fix the furring strips on the exterior side of the panels; through the studs located behind the panels. Space the furring strips and screws as per the recommendations of the manufacturer and as per the plans and specifications.
- 8** Use screws ensuring a penetration in the studs with a minimum of 32 mm [1-1/4"].

➤ MASONRY

- 9** On the air barrier; fix the strips on the exterior side of the panels; through the studs located behind. Space the furring strips and screws as per the recommendations of the manufacturer and as per the plans and specifications.
- 10** Use 8d screws ensuring a penetration in the studs with a minimum of 51 mm [2"].

JUNCTION DETAILS

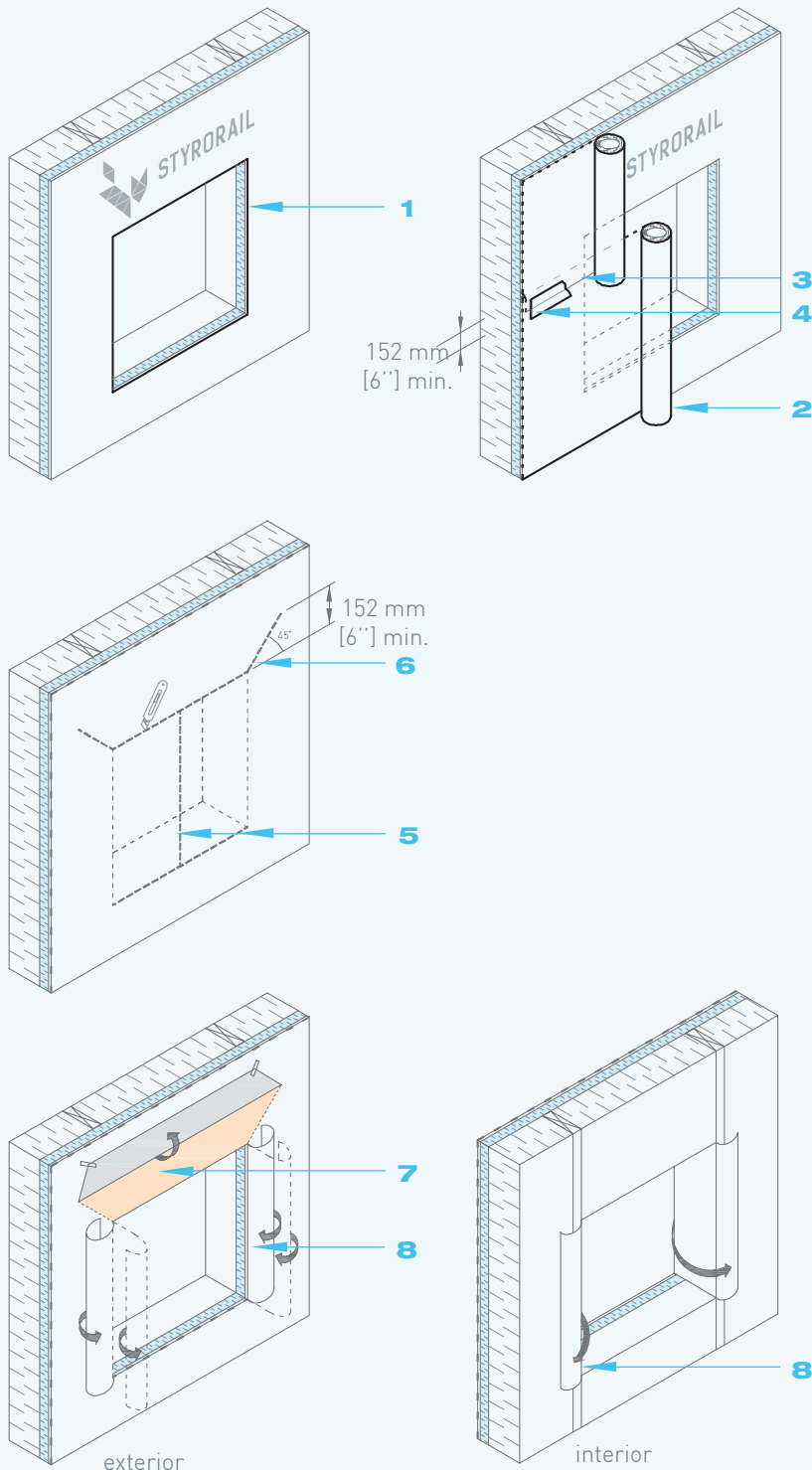

OSB.COMFORT™

© STYRO RAIL™ | 2017-01

▶ OPENING [DOOR AND WINDOW]

- 1 Using a chain saw or a circular saw; cut the panels to adjust them to doors and windows gross dimensions, before the installation. Cut panels flush to the gross opening.
- 2 Install an air barrier in a roll format over the entire panel's surface. Install from the bottom up. Horizontally unfold the roll. Install as per the recommendations of the manufacturer.
- 3 Superimpose the roll on minimum 152 mm [6''] or as per the recommendations of the manufacturer.
- 4 Seal all horizontal and vertical joints between the membranes and around the openings. Use a sealing tape compatible with the air barrier.
- 5 At the openings; cut the air barrier as indicated.
- 6 Cut the air barrier at an angle of 45° on minimum of 150 mm [6''] at the upper corners of the opening.
- 7 Fold back the membrane upward as shown. As necessary, temporarily secure with an adhesive tape in order to facilitate the flexible membrane installation.
- 8 Fold back the membrane toward the interior as shown.

JUNCTION DETAILS

OSB.COMFORT™

© STYRO RAIL™ | 2017-01

▶ OPENING [DOOR AND WINDOW]

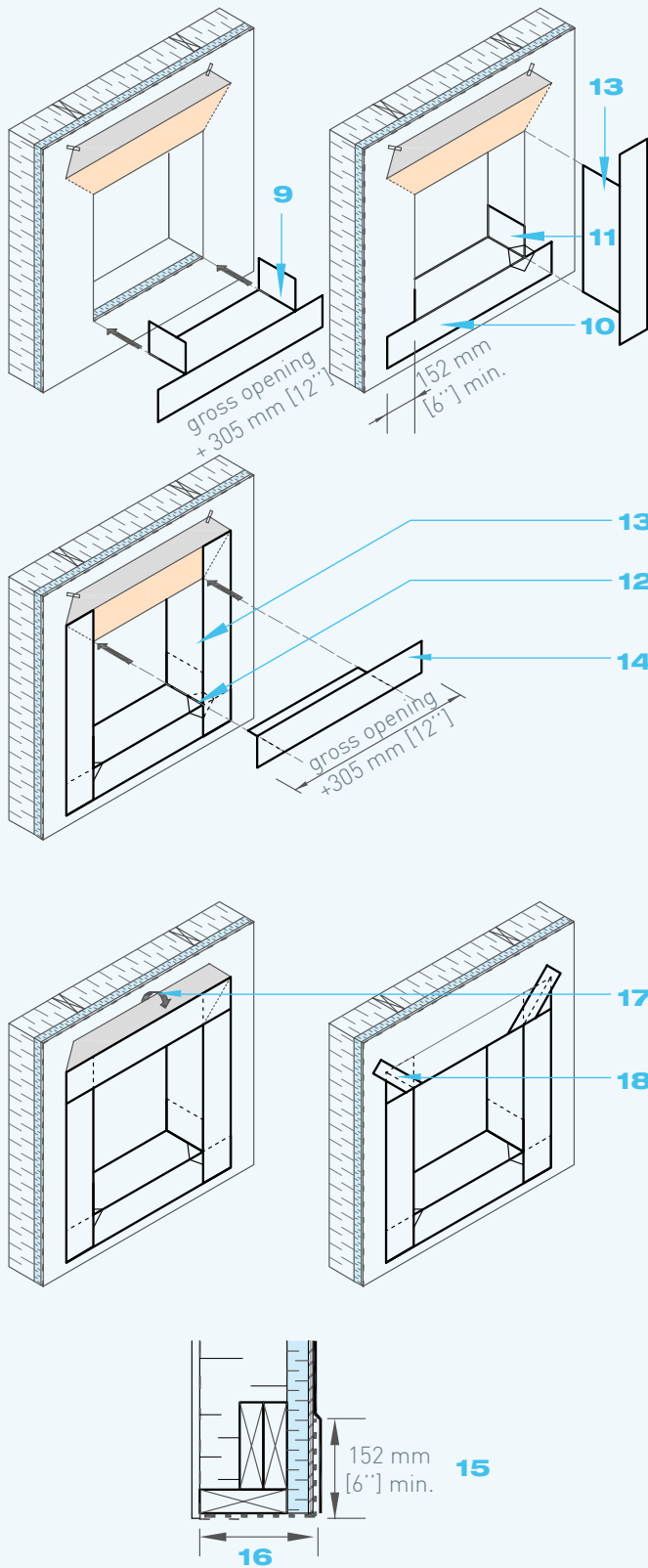

9 Cut the compatible flexible self-adhesive membrane⁺⁺ as shown.

10 Install a compatible flexible self-adhesive membrane⁺⁺ over the entire width of the sill.

11 Fold back the flexible membrane on the air barrier along the opening jambs a minimum of 152 mm [6''].

12 Install a piece of flexible membrane to the bottom corners in order to limit corner air spaces and thus reducing unforeseen water infiltrations.

13 Install a compatible self-adhesive and flexible membrane⁺⁺ along the opening jambs. Overlap every flexible membrane strips minimum 150 mm [6''].

14 Install a compatible self-adhesive and flexible membrane⁺⁺ on lintel.

15 Fold back the flexible membrane on the vertical part of the lintel minimum 150 mm [6''].

16 Fold back the flexible membrane under the lintel, over all lintel width.

17 Fold back the 45° cut air barrier strip over the flexible membrane of the lintel.

18 Seal all joints with compatible sealing tape[†].

JUNCTION DETAILS

OSB.COMFORT™

© STYRO RAIL™ | 2017-01

➤ OPENING [LIGHTWEIGH SIDING]

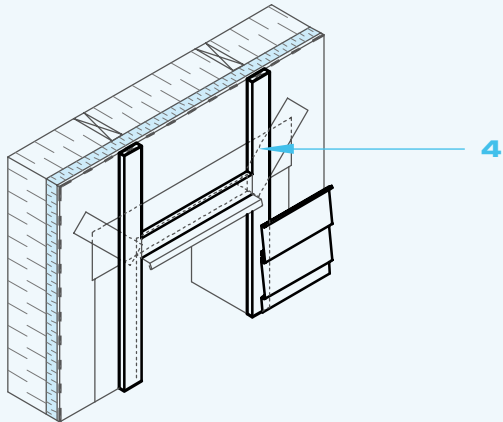
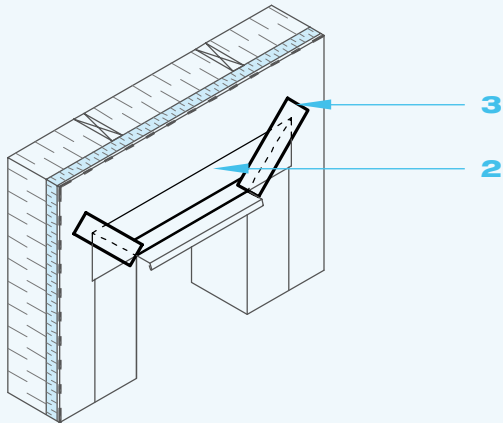
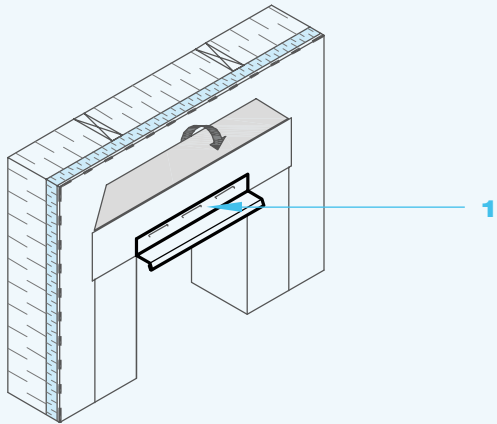

- 1** Fix a compatible drip cap with the cladding according to manufacturer instructions and to plans and specifications.
- 2** Fold back the 45° cut air barrier strip over the flexible membrane of the lintel and over the drip cap.
- 3** Seal all joints with compatible sealing tape†.
- 4** Install the furring strips and the lightweight cladding as per the recommendations of the manufacturer and according to plans and specifications.
- 5** To ensure continuous air and weather tightness of the envelope, seal the empty space between gross opening and window/door framing with an elastomeric sealant or with low expansion foam filling†††.

JUNCTION DETAILS

OSB.COMFORT™

© STYRO RAIL™ | 2017-01

➤ OPENING [MASONRY]

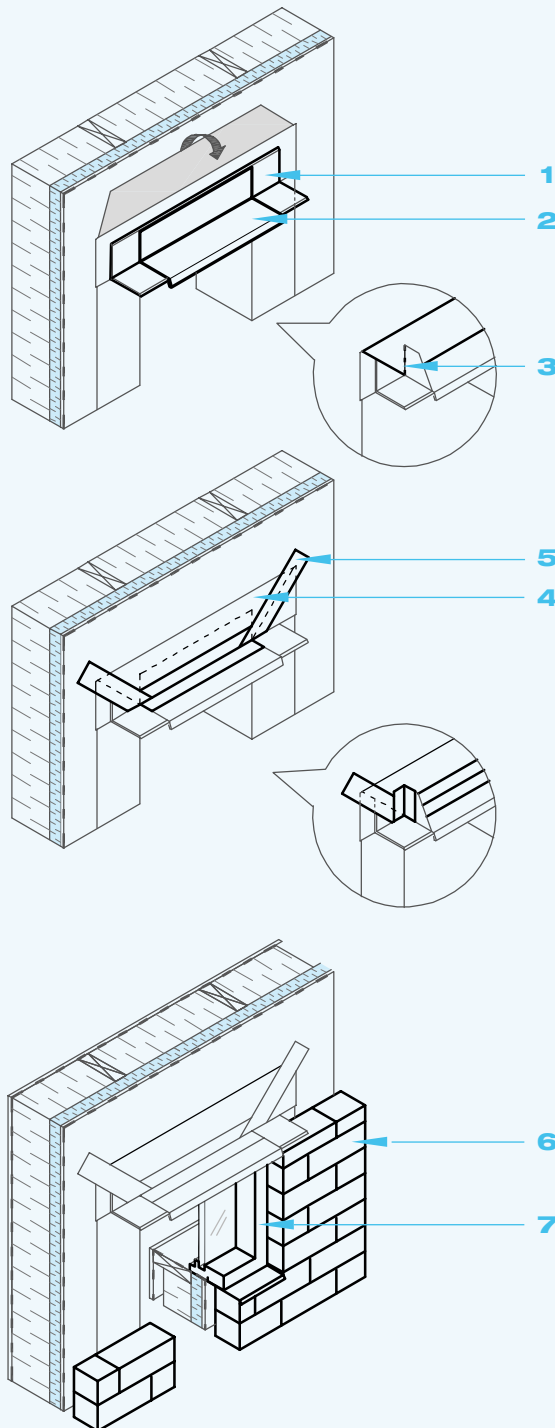

- 1** Fix a metallic angle section as specified by the manufacturer and according to plans and specifications.
- 2** Fix a flashing.
- 3** If the flashing has a "U" form shape, cut off a vertical slot into the air barrier to overtake the vertical part of the flashing.
- 4** Fold forward the 45° cut air barrier strip over the flexible membrane of the lintel.
- 5** Seal all joints with a compatible sealing tape[†].
- 6** Install the masonry as per the recommendations of the manufacturer and according to plans and specifications.
- 7** To ensure continuous air and weather tightness of the envelope, seal the empty space between gross opening and window/door framing with an elastomeric sealant or with low expansion foam filling^{†††}.

JUNCTION DETAILS

OSB.COMFORT™

© STYRO RAIL™ | 2017-01

➤ WALL/ROOF

- 1 Install a strip of air barrier above the wall.
- 2 Leave 400 mm [16''] of the strip on the exterior side of the wall. Overlap the strip over the panels.
- 3 Seal all horizontal and vertical joints between air barrier strip and panels with compatible sealing tape†.

➤ WALL/FOUNDATION

- 4 Cover the joist header and the bottom plate with panels or strips of panels.
- 5 Install a flashing, the vertical part of the flashing behind panel.
- 6 Install an elastomeric sealant between the flashing and the foundation wall.
- 7 Install the air barrier as per the recommendations of the manufacturer and according to plans and specifications.
- 8 Seal all joints between the air barrier and the flashing with compatible flexible membrane†† or with a sealing tape compatible with the surfaces to be jointed†.

➤ INSIDE CORNER

- 9 Install additional studs at corner.
- 10 Nail the panels by allowing a spacing of maximum 152 mm [6''] at the ends and supported edges.

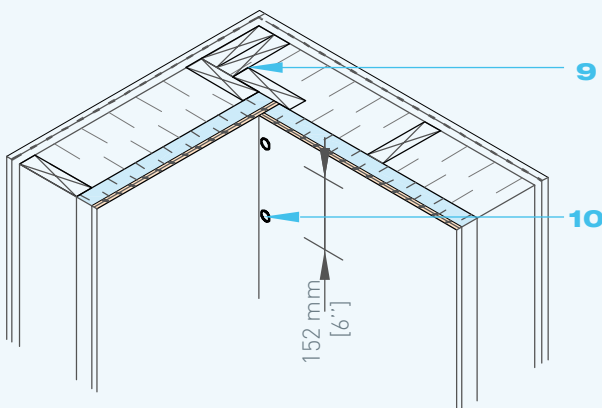
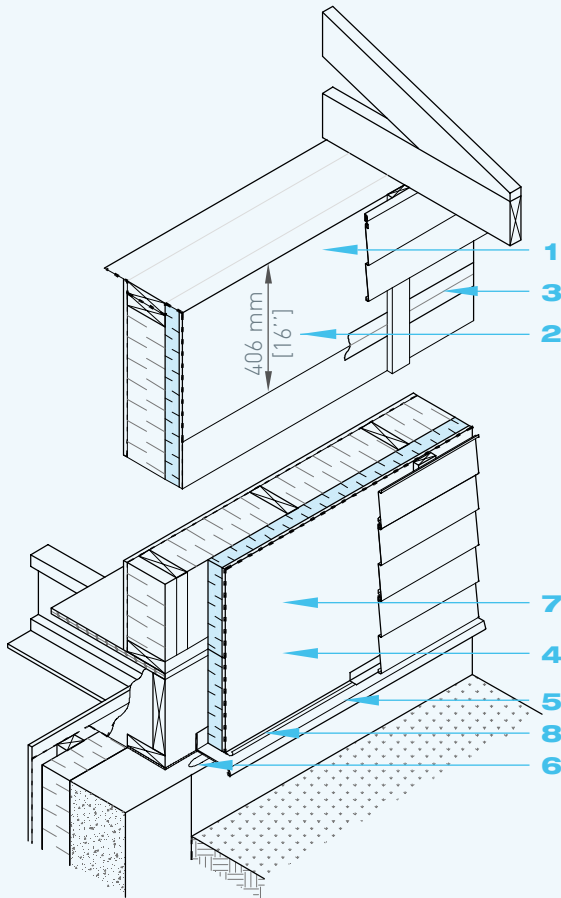

JUNCTION DETAILS

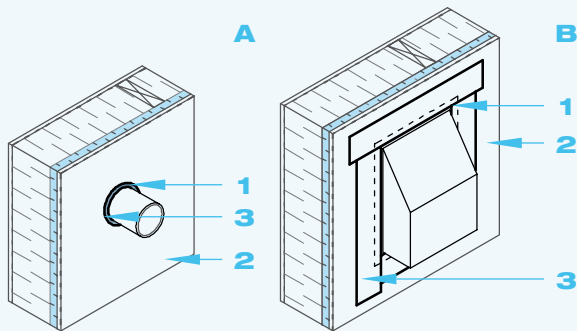

OSB.COMFORT™

© STYRO RAIL™ | 2017-01

➤ PENETRATION [PIPE, DUCT, ELECTRICAL BOX, ETC.]

1 Cut the panels to adjust them to gross opening dimensions.
2 Install an air barrier in a roll format as per the recommendations of the manufacturer.

3 Seal around the object with one of the two following methods. Choose the appropriate method depending on the object to seal.

A Use a compatible elastomeric sealant bead⁺⁺⁺ or,

B Use a compatible sealing tape[†].

GENERAL ADVICES

➤ RECOMMENDED PRODUCTS

† The sealing tape must be air and moisture proof, but permeable to water vapor. It must have previously been evaluated by the Canadian Construction Materials Centre [CCMC] in accordance with the *MasterFormat*® 07 25 20 section and installed according to the related instructions. Validate the sealing tape compatibility with surfaces to be joined.

†† The self-adhesive flexible membrane must be air and moisture proof, but permeable to water vapor. It must be installed according to the manufacturer's instructions. The *Blueskin*® SA or WP from *Henry Baker* and *Hi-tac* primer from *Henry Baker* are compatible with expanded polystyrene and air-barrier membrane. Validate the self-adhesive flexible membrane compatibility with other surfaces to be joined and manufacturer's restrictions.

††† Sealants must be compatible with expanded polystyrene. Use *ADFoam* from *ADFast* polyurethane insulating foam or equivalent. Especially validate the sealant compatibility with utilized self-adhesive flexible membrane.

➤ STORAGE AND COVERING

Store panels in a dry location, protected from the outside elements, ultraviolet rays, open flames or other sources of ignition. Stack panels on pallets of minimum 100 mm [4"] above the ground. If provided packaging has been damaged during shipping, cover panels with a weather and ultraviolet tarp. Panels must be dry and in good condition before installation.

➤ EXEMPTION FROM LIABILITY

The information herein is based on the present state of our best scientific and practical knowledge. They are provided to facilitate Styro Rail™ product's installation and may not apply to all situations. The user is responsible for checking the suitability of products for their intended use. Styro Rail™ installation guides are updated on a regular basis; it is the user's responsibility to obtain and to confirm the most recent version. Information contained in this data sheet may change without notice. The drawings and details herein have not been scaled up.



Expand your world

Styro Rail Inc. 65 Route 105, La Pêche, Québec J0X 3G0
T 1 819 643-4456 1 888 332-3456 F 819 459-1621

