



INSTALLATION GUIDE

The **SR.HydroPex™** panels manufactured by Styro Rail™ are composed of type 2 [200 series] expanded polystyrene [EPS] rigid insulation or type 3 [300 to 600 series]. A honeycomb-layout creates a spacing with intervals of 762 mm [3'] for the placement of the pipes. The system is compatible with all pipes dimensions: 13 mm [1/2"], 16 mm [5/8"], 20 mm [3/4"] and 25 mm [1"].

➤ RECOMMENDED USE

Install **SR.HydroPex™** panels as an insulating material that offers a support to fix water or glycol radiant heat floor pipes. Install 200 series prior to the pouring of finished concrete of basement slabs and residential garages; 300 to 600 series for commercial, industrial and agricultural concrete slabs.

➤ PANEL DESCRIPTION

A Expanded Polystyrene Rigid Insulation Panel [EPS] type 2 or type 3 molded by Styro Rail™

B 19 mm [3/4"] Overlap on 4 sides

C Dome

D Honeycomb Layout

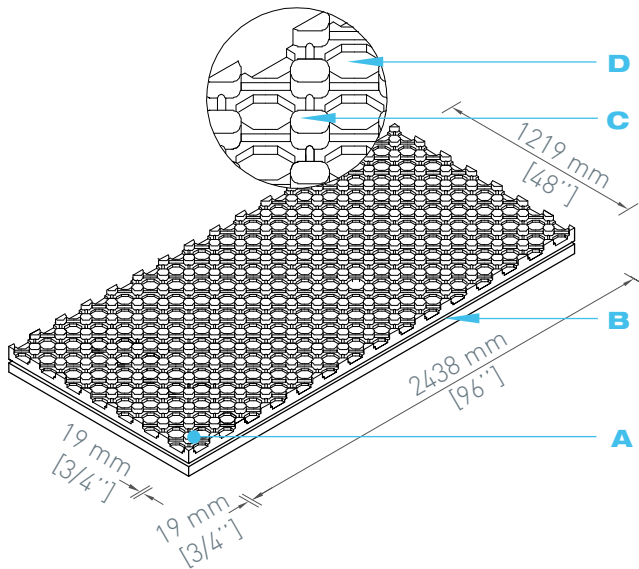

PANEL INSTALLATION

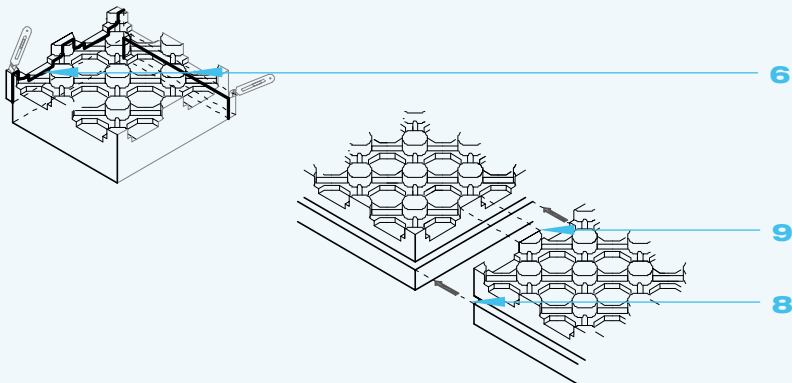
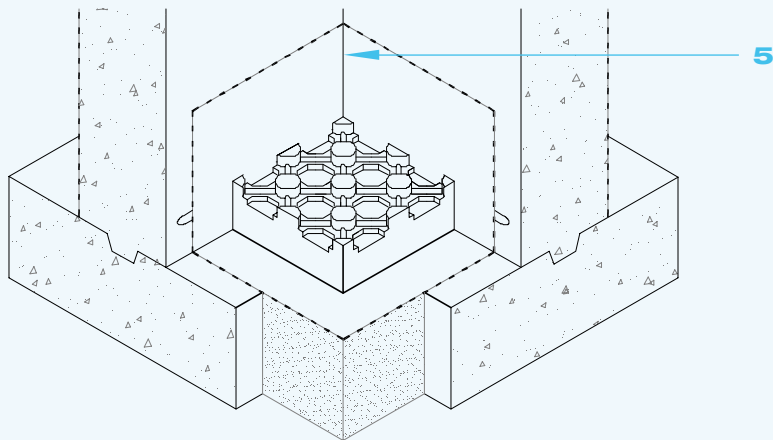
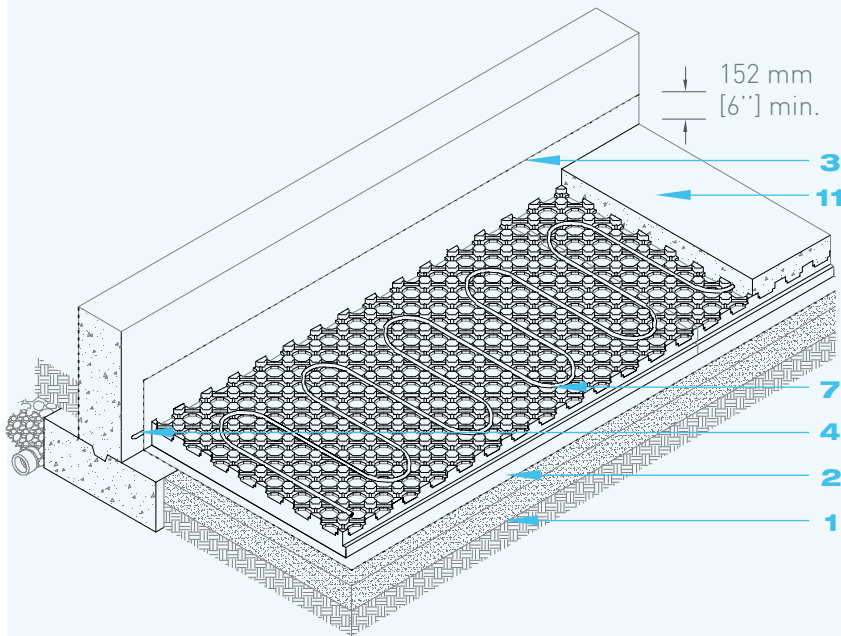

SR.HYDROPEX™

© STYRO RAIL™ | 2017-01

➤ GENERAL INSTALLATION

- 1** Compact the back fill material.
- 2** Install a vapour barrier on the footings and over the back fill material.
- 3** Leave a vapour barrier strip at the bottom of the foundation wall. Leave a minimum of 152 mm [6''] over the concrete slab.
- 4** Apply an acoustic sealant bead between vapour barrier and foundation wall. Press firmly on the vapour barrier.
- 5** Begin the installation on an interior corner of the foundation.
- 6** Using a knife with a retractable blade, cut ship laps that will butt against the wall.
- 7** Install the **SR.HydroPex™** panel on the vapour barrier. Butt ends between panels. Install panels continuously and uniformly.
- 8** Continue installation by overlapping joints.
- 9** Align domes between panels.
- 10** Follow the steps described in this present guide to install the panels and the pipes.
- 11** Pour the concrete slab.

PANEL INSTALLATION

SR.HYDROPEX™

© STYRO RAIL™ | 2017-01

➤ FINISHING SLAB [BASEMENT]

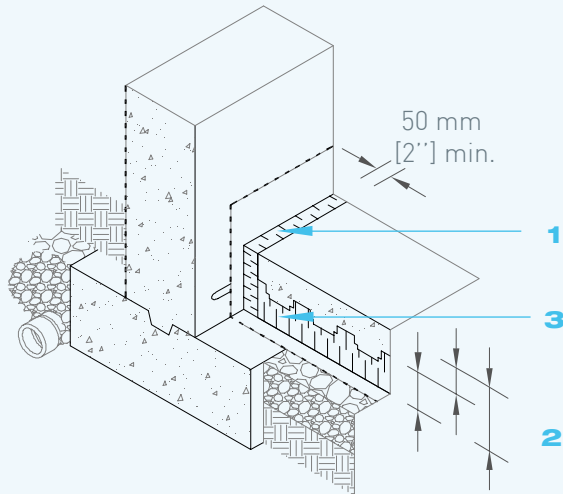

- 1** Install a type 2 expanded polystyrene strip of minimum 50 mm [2"]* in thickness on the vertical section of the vapor barrier.
- 2** Calculate the height of the expanded polystyrene strip with the thickness of the **SR.HydroPex™** panel and the concrete slab.
- 3** Install panels as described in this guide.

* The expanded polystyrene strip can be reduced to 32 mm [1-1/4"] for the basement finishing slabs that does not contain ducts, heating pipe system or buried cables and that are located at least at 610 mm [24"] under the soil level.

PANEL INSTALLATION

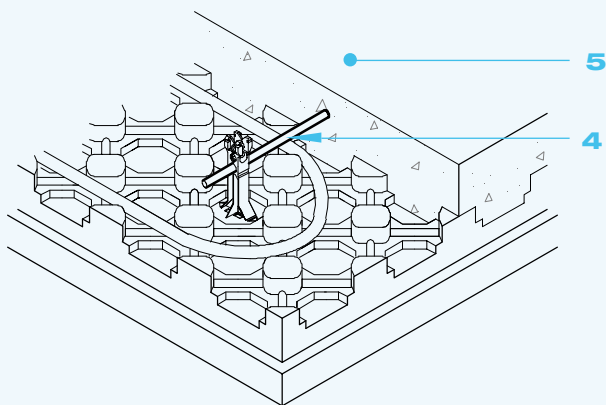
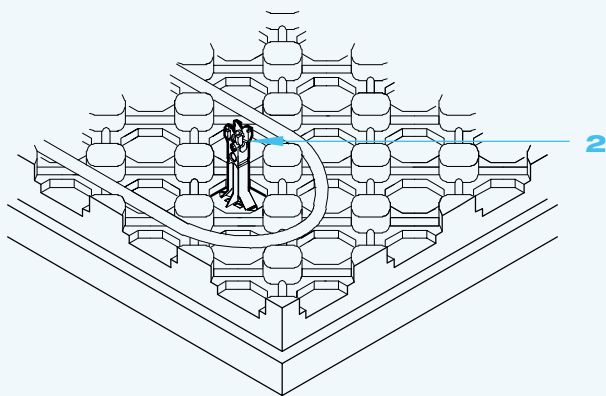
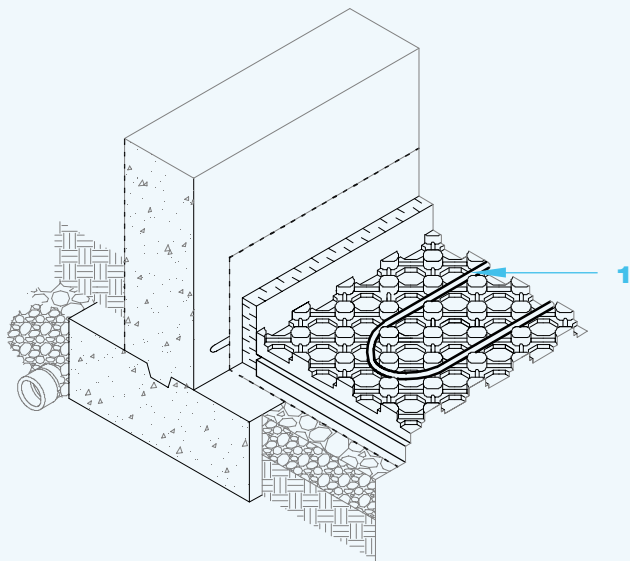

SR.HYDROPEX™

© STYRO RAIL™ | 2017-01

PIPE

1 Insert pipes between domes depending on the configuration and space required by the installer or according to plans and specifications.

REBAR

2 When rebars are required, insert *Prolok*® fasteners in the hollow part of the honeycomb layout. Allow for the spacing indicated in the plans and specifications or as per the spacing recommended by the ties manufacturer.

3 Insert *Prolok*® fasteners after pipes installation.

4 Insert rebars into *Prolok*® fasteners.

5 Pour the concrete slab.

JUNCTION DETAILS

SR.HYDROPEX™

© STYRO RAIL™ | 2017-01

➤ OPENINGS AND PIPING

- 1 Seal the perimeter of the object using a vapour barrier tape.
- 2 Using a knife with a retractable blade or a drywall saw, cut panel on object perimeter.
- 3 Install **SR.HydroPex™** panel through the object.

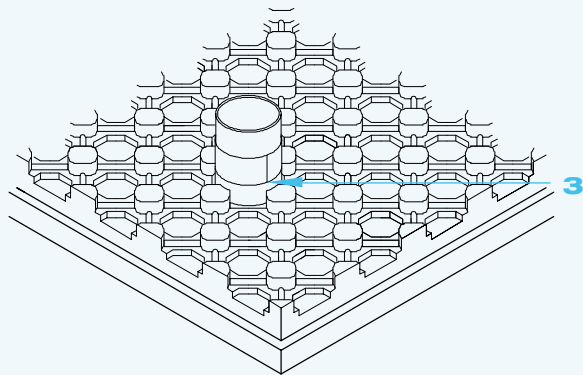
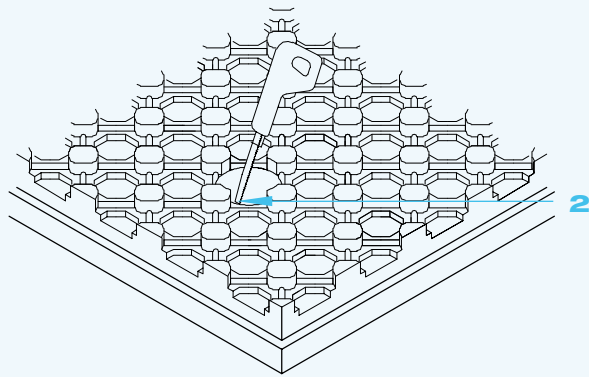
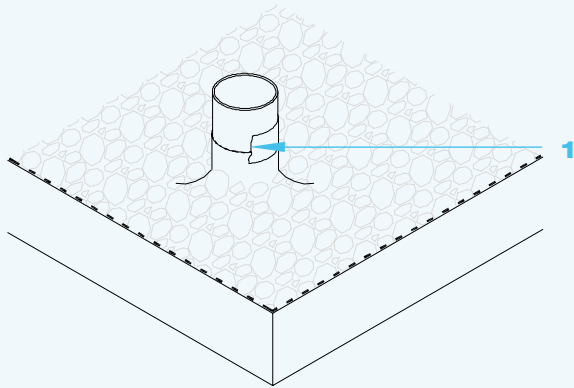

GENERAL ADVICES

➤ STORAGE AND COVERING

Store panels in a dry location, protected from the outside elements, ultraviolet rays, open flames or other sources of ignition. Stack panels on pallets of minimum 100 mm [4"] above the ground. If provided packaging has been damaged during shipping, cover panels with a weather and ultraviolet tarp. Panels must be dry and in good condition before installation.

➤ EXEMPTION FROM LIABILITY

The information herein is based on the present state of our best scientific and practical knowledge. They are provided to facilitate Styro Rail™ product's installation and may not apply to all situations. The user is responsible for checking the suitability of products for their intended use. Styro Rail™ installation guides are updated on a regular basis; it is the user's responsibility to obtain and to confirm the most recent version. Information contained in this data sheet may change without notice. The drawings and details herein have not been scaled up.



Expand your world

Styro Rail Inc. 65 Route 105, La Pêche, Québec J0X 3G0
T 1 819 643-4456 1 888 332-3456 F 819 459-1621

