

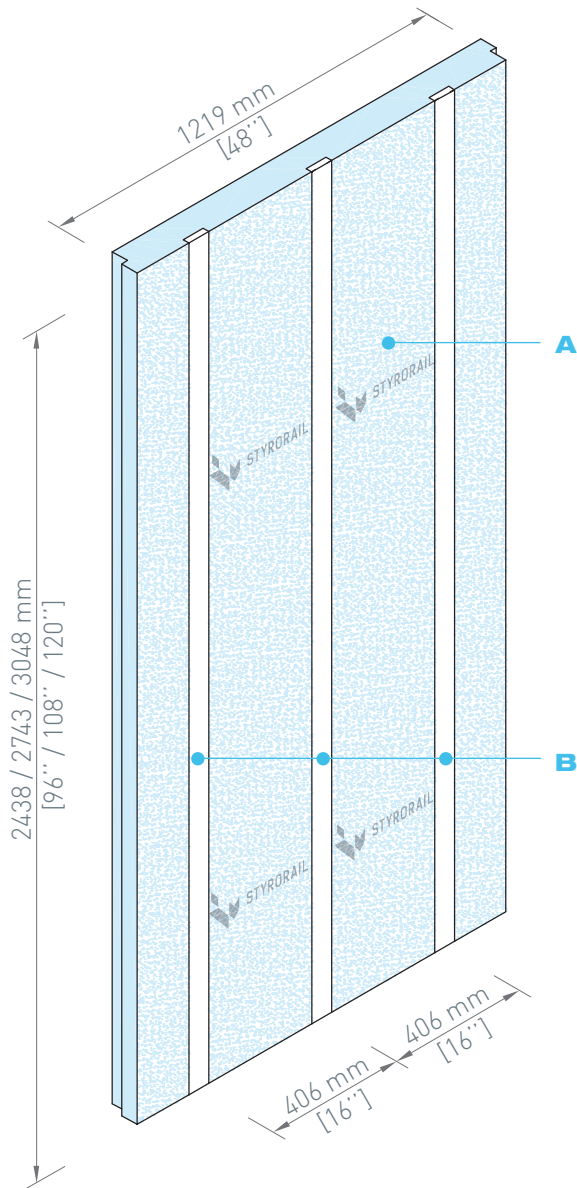

INSTALLATION GUIDE



The **SR.I™** panels manufactured by Styro Rail™ are composed of type 1 [100 series] or type 2 [200 series] expanded polystyrene [EPS] rigid insulation in which 25 mm x 76 mm [1'' x 3''] wooden furs are embedded at every 406 mm [16''] o.c.

➤ RECOMMENDED USE

SR.I™ panels are versatile and can be used in many applications requiring the fastening of finished material. Install **SR.I™** panels on the interior surface of foundation walls, flat and cathedral ceilings in order to obtain a continuous thermal envelope. Ideal when space is limited.

➤ PANEL COMPOSITION

A Type 1 or Type 2 Expanded Polystyrene Rigid Panel Insulation [EPS] manufactured by Styro Rail™

B 19 mm x 64 mm [1'' x 3''] furring strips at 406 mm [16''] o.c.

PANEL INSTALLATION

SR.I™

© STYRO RAIL™ | 2017-01

GENERAL FIXATION

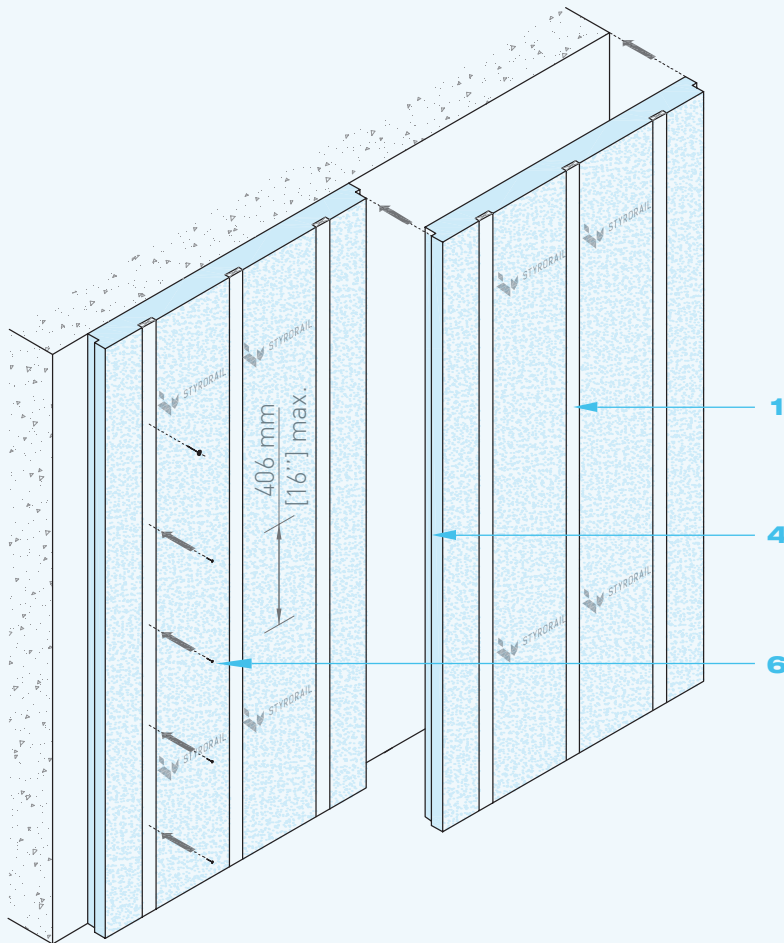

- 1** Install panels vertically or horizontally. Position the panel in order to see the furring strips.
- 2** Start the installation on an interior corner.
- 3** Cut off the ship lap of the first panel using a knife with a retractable blade.
- 4** Install from left to right. Install panels continuously and uniformly. Butt ends between panels.
- 5** As necessary, pre-drill the furring strip and the wall with an impact drill as per the recommendations in this guide.
- 6** Nail the panels through the furring strips with a spacing of 406 mm [16"] max.
- 7** Use nails or screws ensuring a penetration in the structure of minimum 32 mm [1-1/4"].

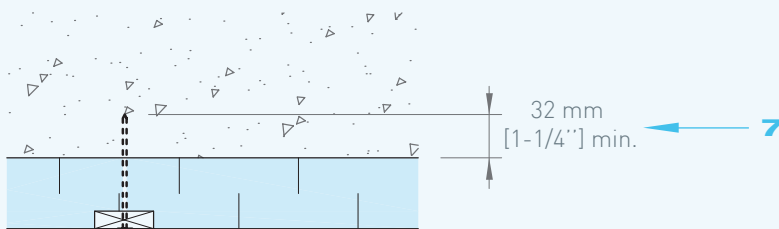
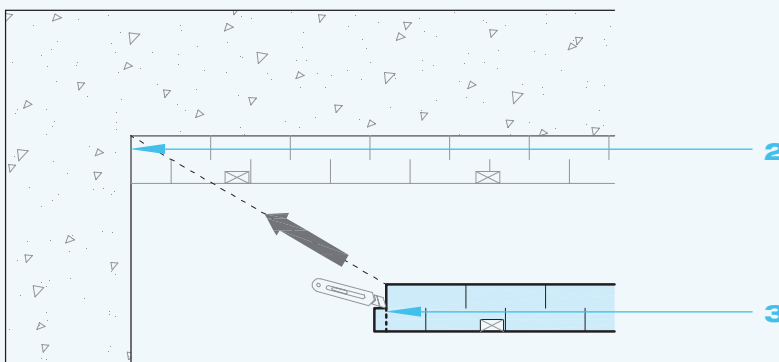

PANEL INSTALLATION

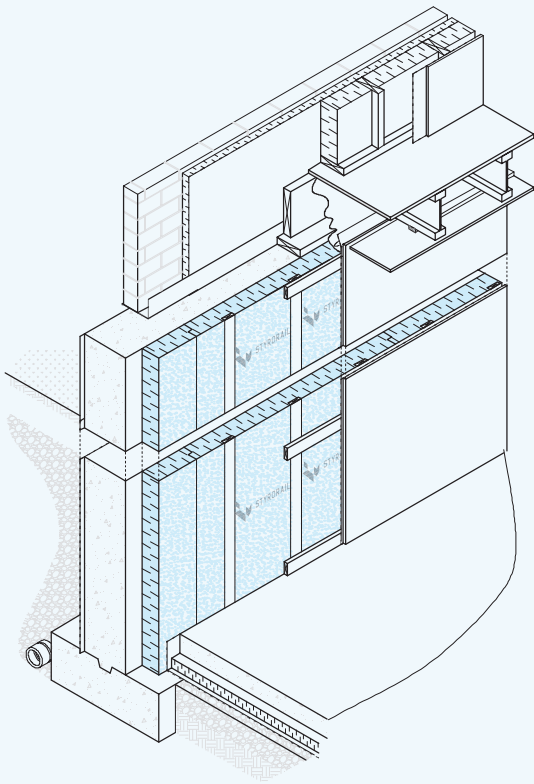

SR.I™

© STYRO RAIL™ | 2017-01

➤ FOUNDATION WALL [NEW CONSTRUCTION]

- 1** Install panels directly on the footing, before the concrete pour.
- 2** Apply an acoustic sealant[†] at the bottom of the panel.
- 3** Install and seal a vapor barrier on the fill material and on the footing.
- 4** Leave a minimum 305 mm [12"] strip at the bottom of the wall. Fold back the strip on the wall. Temporarily secure with an adhesive tape.
- 5** Install expanded polystyrene insulating panels on ground, above the vapor barrier. Pour the concrete slab.
- 6** Fold forward the vapor barrier on the concrete slab.

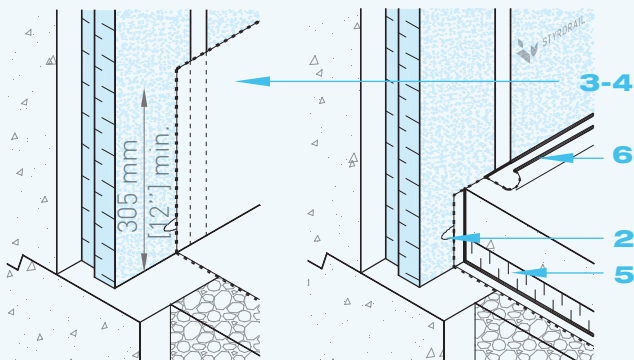
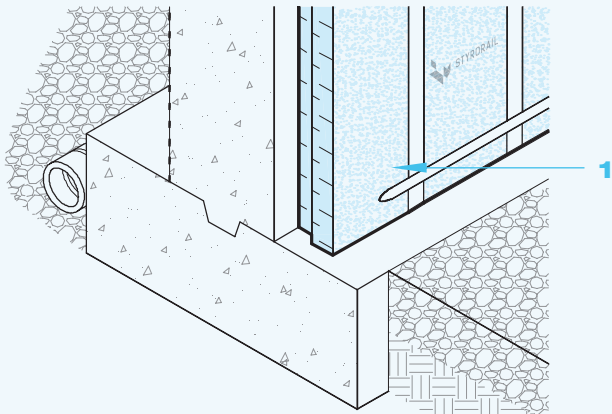

JUNCTION DETAILS

SR.I™

© STYRO RAIL™ | 2017-01

▶ FOUNDATION WALL [NEW CONSTRUCTION]

- 7** Fix the 19 mm x 64 mm [1" x 3"] furring strips horizontally to integrated furring strips in insulating panels.
- 8** Allow a maximum spacing of 610 mm [24"] o.c. between furring strips. Use nails or screws of 51 mm [2"] min.
- 9** Install and seal a vapor barrier on the wall.
- 10** Fold back the vapor barrier of the concrete slab on the wall vapor barrier.
- 11** Seal junctions of the vapor barrier with a compatible sealing tape.
- 12** Install a protective barrier such as gypsum boards.

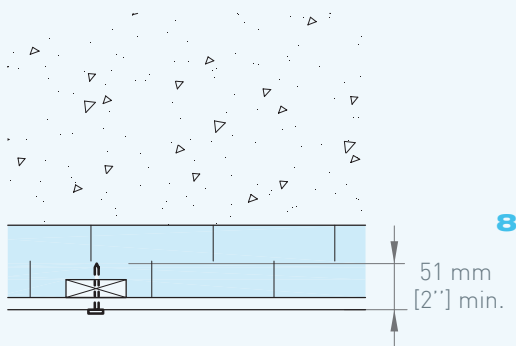
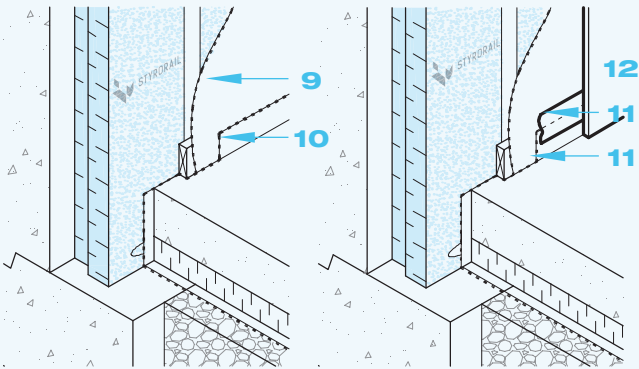
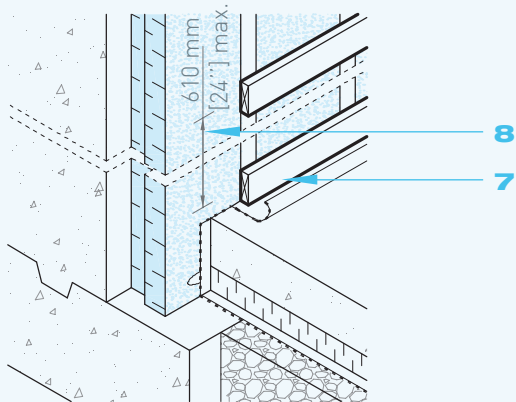

JUNCTION DETAILS

SR.I™

© STYRO RAIL™ | 2017-01

FOUNDATION WALL [RENOVATION]

EXISTING CONCRETE SLAB WITH VAPOR BARRIER

- 1 If a vapor barrier strip exceed at the bottom of the foundation wall; fold back on the concrete slab before the panel's installation.
- 2 Install insulating panels on concrete slab, above the vapor barrier.
- 3 Fix the 19 mm x 64 mm [1" x 3"] furring strips horizontally to integrated furring strips in insulating panels.
- 4 Allow a maximum spacing of 610 mm [24"] o.c. Use nails or screws of 51 mm [2"] min.
- 5 Install and seal a vapor barrier on the wall.
- 6 Fold back the vapor barrier of the concrete slab on the wall vapor barrier.
- 7 Seal junctions of the vapor barrier with a compatible sealing tape.
- 8 Install a protective barrier such as gypsum boards.

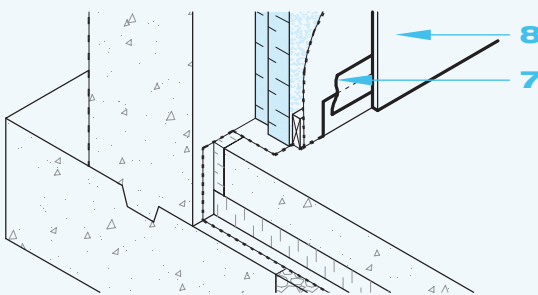
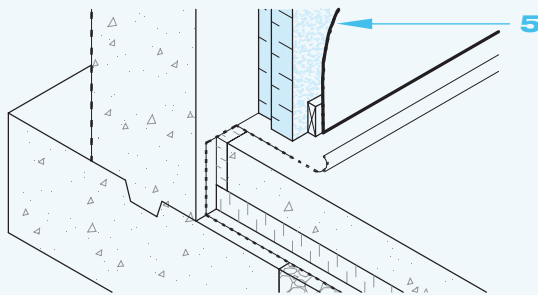
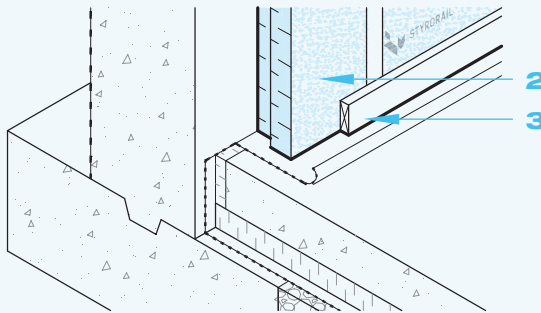
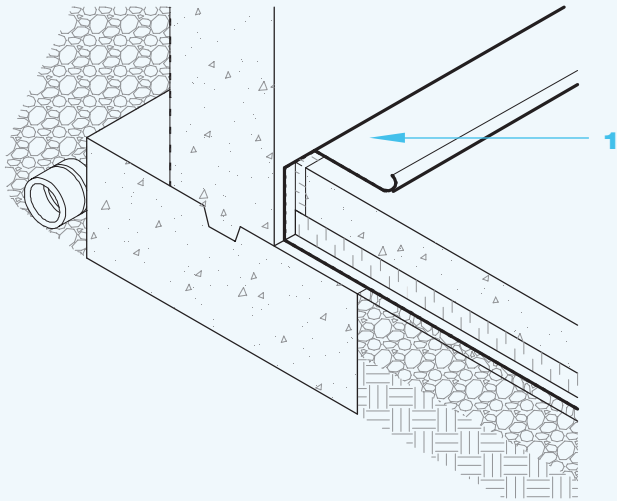

JUNCTION DETAILS

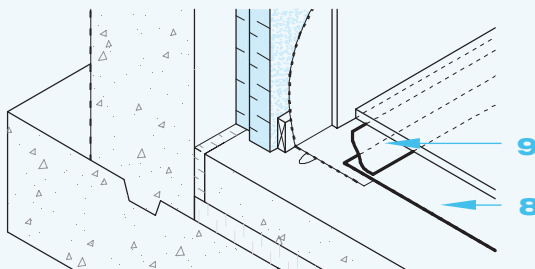
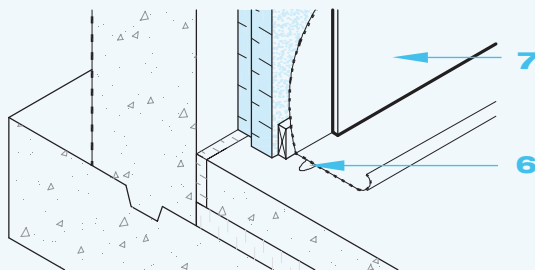
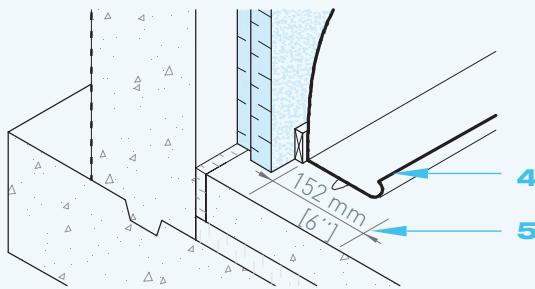
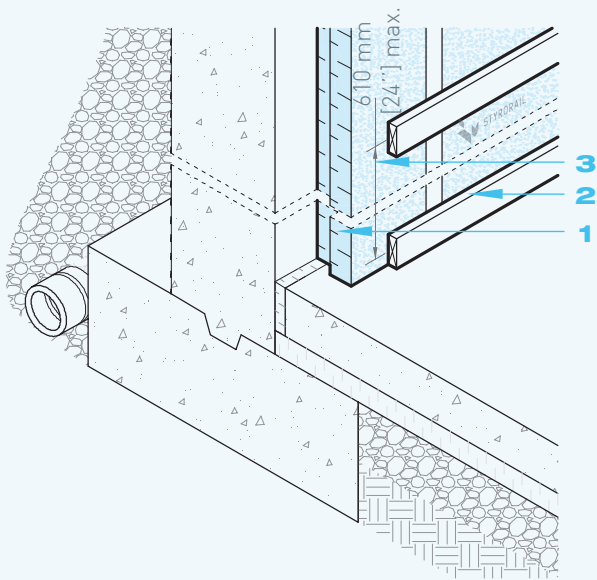

SR.I™

© STYRO RAIL™ | 2017-01

FOUNDATION WALL [RENOVATION]

EXISTING CONCRETE SLAB WITHOUT VAPOR BARRIER

- 1 Install panels directly on the concrete slab.
- 2 Fix the 19 mm x 64 mm [1" x 3"] furring strips horizontally to integrated furring strips in insulating panels.
- 3 Allow a maximum spacing of 610 mm [24"] o.c. Use nails or screws of 51 mm [2"] min.
- 4 Install a vapor barrier.
- 5 Leave a minimum 152 mm [6"] strip at the bottom of the wall, on the concrete slab.
- 6 Apply an acoustic sealant[†] bead between the concrete slab and the vapor barrier.
- 7 Install a protective barrier such as gypsum boards.
- 8 During the floor installation, install a vapor barrier underneath according to the manufacturer's instructions.
- 9 Seal the vapor barrier joints with compatible sealing tape.

JUNCTION DETAILS

SR.I™

© STYRO RAIL™ | 2017-01

➤ ROOF / CEILING

- 1** Install panels in such a way that the panel furring strips are perpendicular to roof/ceiling structure elements. Install on the interior surface of the ceiling in order to see the furring strips.
- 2** Fix panels through the furring strips and into the roof/ceiling structure.
- 3** Use nails or screws ensuring a penetration in the structure of minimum 32 mm [1-1/4"'].]
- 4** Install and seal a vapor barrier.
- 5** Install a protective barrier such as gypsum boards.

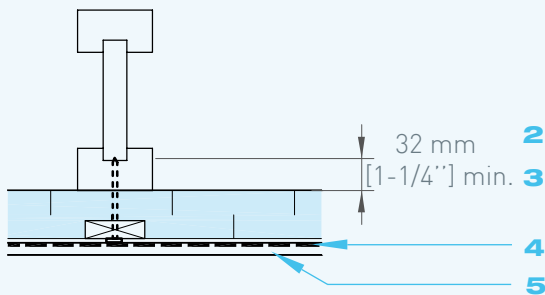
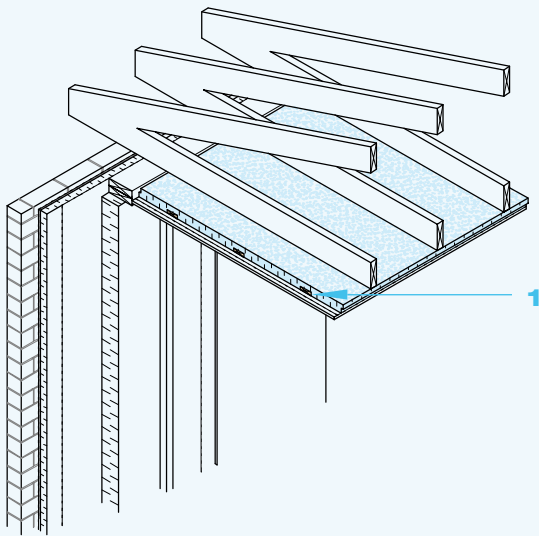
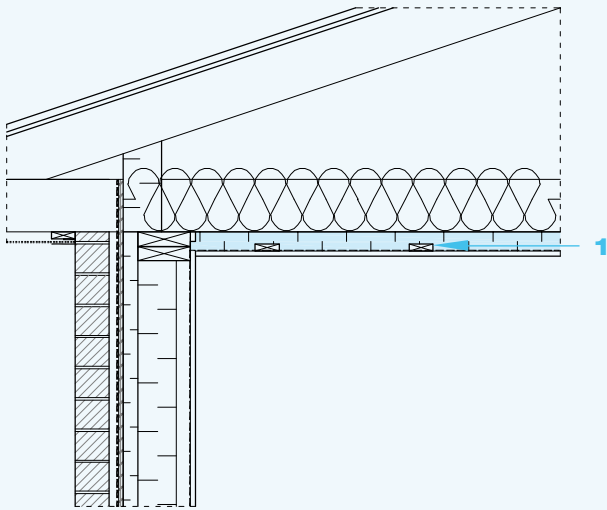

PANEL INSTALLATION

SR.I™

© STYRO RAIL™ | 2017-01

➤ CORNER

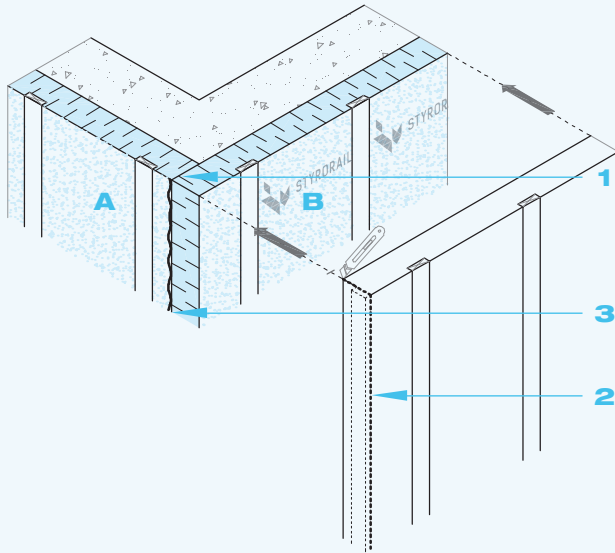

1 Cut the panel [A] using a knife with a retractable blade or a circular-saw. Align the panel with the corner of the foundation wall.

2 Cut the ship lap of the panel [B]. Install panel [B].

3 Spray a urethane bead⁺⁺ at the corner in order to fill the cavity which may have formed during the cutting of the insulation.

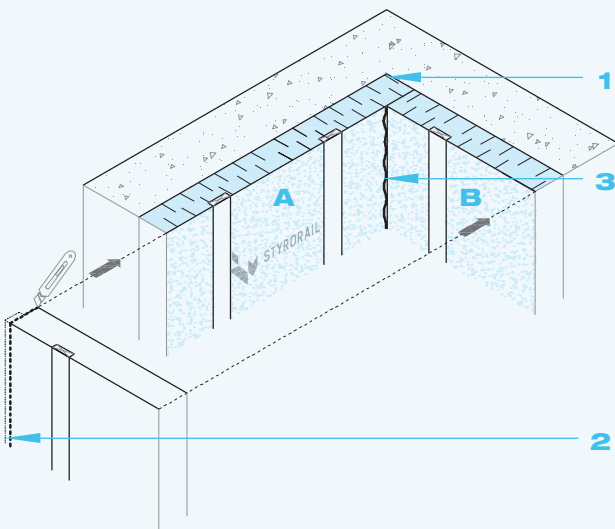

GENERAL ADVICES

➤ RECOMMENDED PRODUCTS

† The acoustic sealant must be compatible with expanded polystyrene. Use *Tremco* acoustic sealant or equivalent.

†† Sealants must be compatible with expanded polystyrene. Use *ADFoam* from *ADFast* polyurethane insulating foam or equivalent.

➤ STORAGE AND COVERING

Store panels in a dry location, protected from the outside elements, ultraviolet rays, open flames or other sources of ignition. Stack panels on pallets of minimum 100 mm [4''] above the ground. If provided packaging has been damaged during shipping, cover panels with a weather and ultraviolet tarp. Panels must be dry and in good condition before installation.

➤ EXEMPTION FROM LIABILITY

The information herein is based on the present state of our best scientific and practical knowledge. They are provided to facilitate Styro Rail™ product's installation and may not apply to all situations. The user is responsible for checking the suitability of products for their intended use. Styro Rail™ installation guides are updated on a regular basis; it is the user's responsibility to obtain and to confirm the most recent version. Information contained in this data sheet may change without notice. The drawings and details herein have not been scaled up.



Un monde en expansion

Styro Rail Inc. 65 Route 105, La Pêche, Québec J0X 3G0
T 1 819 643-4456 1 888 332-3456 F 819 459-1621

