

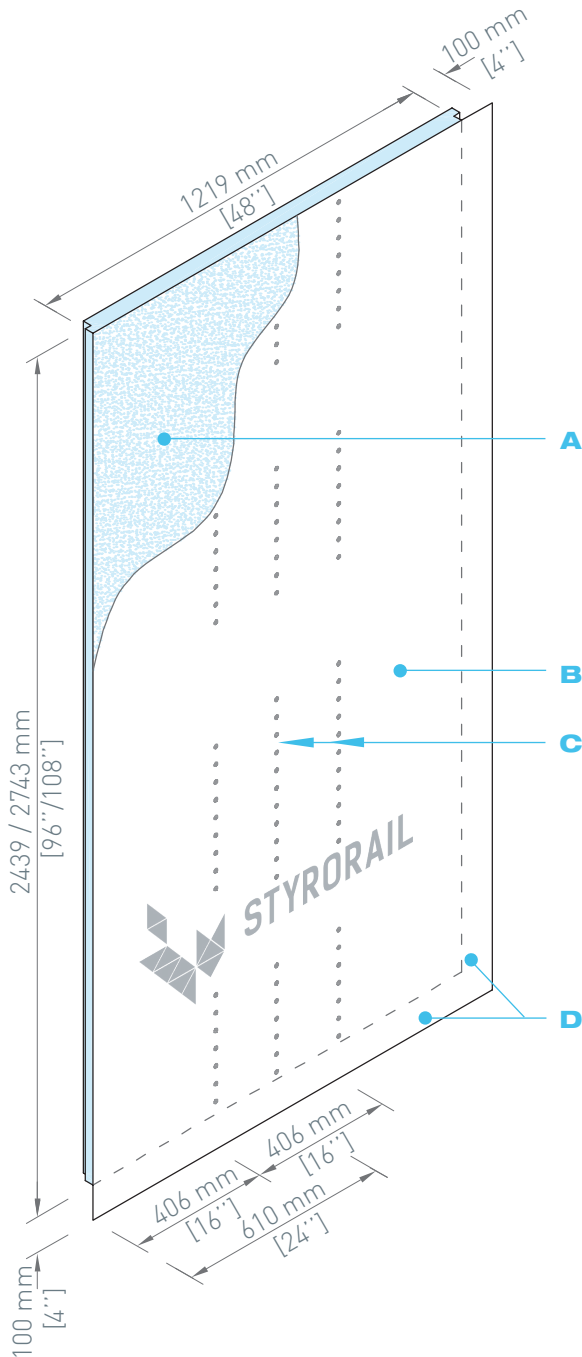

INSTALLATION GUIDE



The SR.AirTM200 panels manufactured by Styro RailTM are composed of type 2 expanded polystyrene [EPS] rigid insulation laminated to an air and weather barrier.

➤ RECOMMENDED USE

Install SR.AirTM200 panels on the exterior surface of framed walls in order to obtain a continuous thermal envelope, a barrier against potential air infiltration beneath the exterior siding and in order to limit unforeseen water infiltrations.

➤ PANEL COMPOSITION

A Type 2 Expanded Polystyrene Rigid Panel Insulation [EPS] manufactured by Styro RailTM

B Air and weather barrier membrane made of a multi-layered hybrid composition [woven]

C Dotted lines printed at 16" and 24", that facilitate the location of the studs behind the panels

D 100 mm [4"] air barrier overlap on two sides [at the junction of the panels]

PANEL INSTALLATION

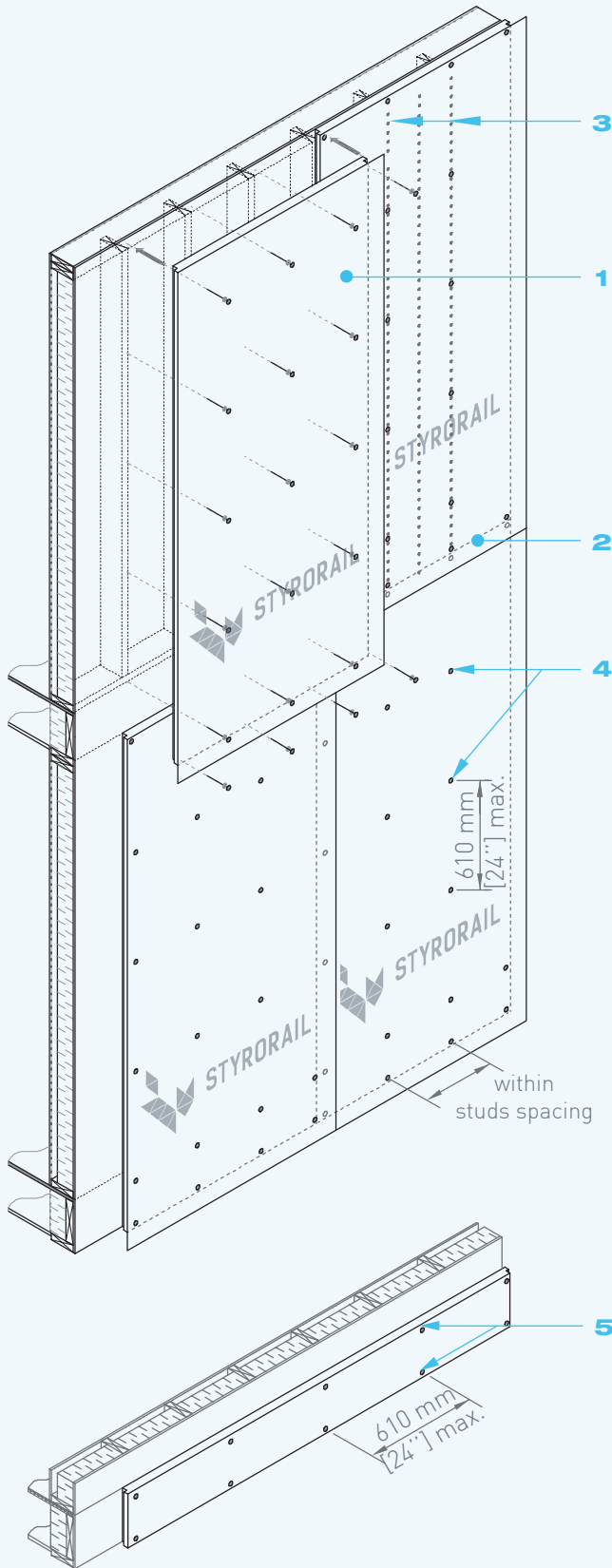

GENERAL FASTENING

- 1** Install panels, from the bottom up, printed side of the air barrier on the exterior side. Install panels continuously and uniformly. Butt ends between panels.
- 2** Panels can be installed vertically or horizontally as long as one of the two overlap is located at the bottom of the panel; in order to ensure outward water drainage.
- 3** If panels are installed vertically, coincide dotted lines with studs located behind the panels; in order to facilitate locating the studs after panels are installed.
- 4** Nail panels with a spacing of 600 mm [24"] o.c. along ends of panels, supported panel ends and along the intermediate studs. Use plastic ring shape nails with a minimum of 25 mm [1"] diameter head.
- 5** For a new construction, nail a SR.AirTM200 strip along the joist header with a spacing of 600 mm [24"] o.c. on the lower and upper edges.

PANEL INSTALLATION

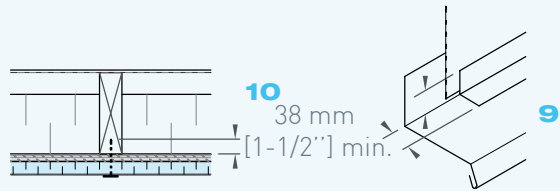
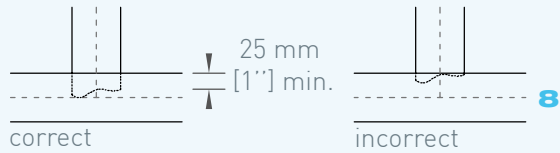
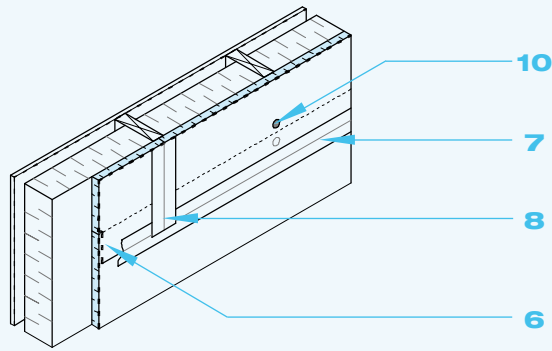

CLADDING INSTALLATION

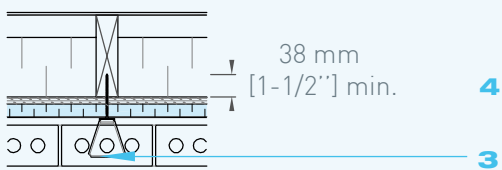
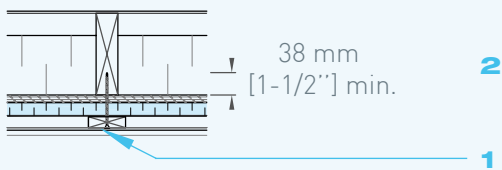

GENERAL FASTENING [CONTINUED]

- 6** Overlap excess part of the air barrier on the adjacent panels.
- 7** Seal all horizontal and vertical joints between panels and around the openings with compatible sealing tape⁺.
- 8** Where two sealing tapes meet, overlap tapes on at least 25 mm [1"].
- 9** When sealing a angled edge, overlap tape equally on each sides of the angle line.
- 10** Use nails ensuring a penetration in the studs of 38 mm [1-1/2"] min.

LIGHTWEIGHT CLADDING

- 1** Fix furring strips on the exterior side of the panels, through panels and on studs located behind the panels. Space and screw furring strips as recommended by the lightweight cladding manufacturer and according to plans and specifications.
- 2** Use screws ensuring a penetration in the studs of 38 mm [1-1/2"] min.

MASONRY

- 3** Fix metal ties on the exterior side of panels, through panels and on studs located behind the panels. Fix and space ties according to ties manufacturer's instructions and according to plans and specifications.
- 4** Use ties ensuring a penetration in the studs of 38 mm [1-1/2"] min.

PANEL INSTALLATION

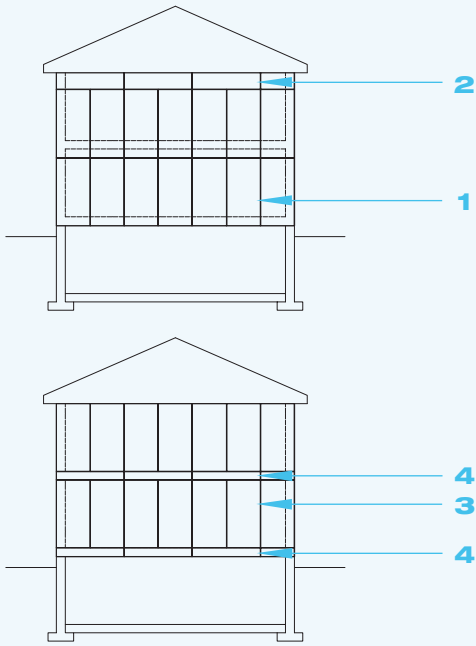

JUNCTION DETAILS

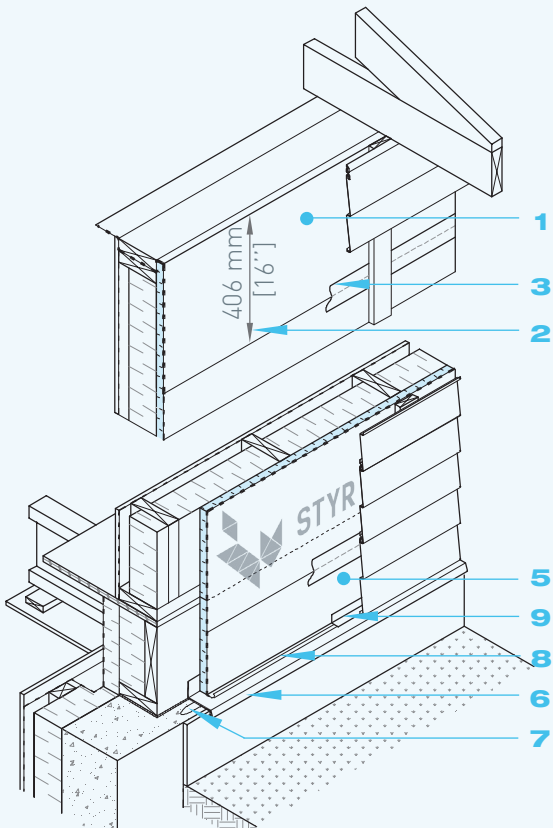

SR.AIR²⁰⁰™

© SR.AIR™ | 2020-02

RENOVATION INSTALLATION

- 1 Install panels on framework, from the bottom up.
- 2 If covered height does not allow full-size panels installation, cut strips of panels accordingly to necessary dimensions to fill the upper space of the wall. Fix strips as per the installation method described in this guide.

NEW CONSTRUCTION INSTALLATION

- 3 Install panels on framework, prior to erecting the walls.
- 4 Cut panel strips accordingly to the dimensions to fill the space towards the joist header. Fix strips as per the installation method described in this guide.

WALL/ROOF

- 1 Install a strip of air barrier above the wall.
- 2 Leave 400 mm [16''] of the strip on the exterior side of the wall. Overlap the strip over the SR.Air™200 panels.
- 3 Seal all horizontal and vertical joints between air barrier strip and panels with compatible sealing tape[†].

INTERMEDIATE PANEL

- 4 Seal all horizontal and vertical joints between panels with compatible sealing tape[†].

WALL/FOUNDATION

- 5 Cover the joist header and the bottom plate with SR.Air™200 panels or strips of SR.Air™200 panels.
- 6 Install a flashing, the vertical part of the flashing behind panel.
- 7 Apply a compatible acoustic sealant bead^{††} between flashing and foundation wall.
- 8 As necessary, cut the excess bottom part of the air barrier before sealing the panel to the flashing.
- 9 Seal all the joints between panels and flashing with a compatible flexible membrane^{††} or with a compatible sealing tape with the flashing[†].

JUNCTION DETAILS

SR.AIR²⁰⁰™

© SR.AIR™ | 2020-02

➤ OPENING [DOOR AND WINDOW]

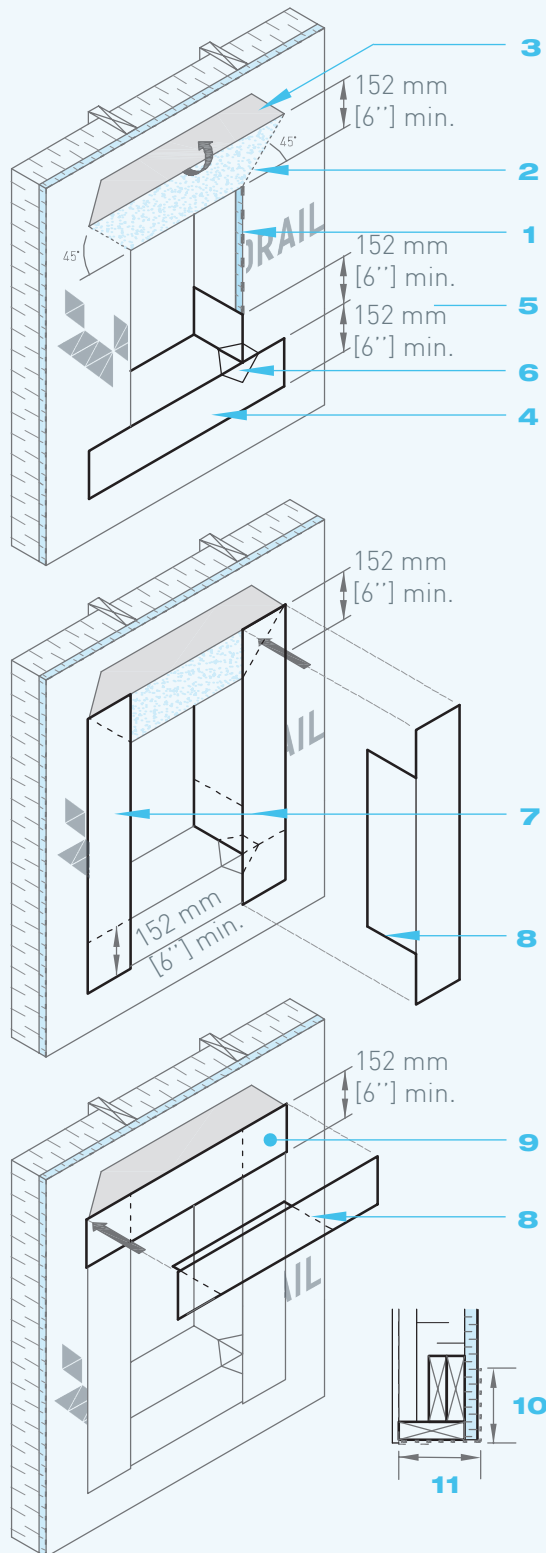

- 1** Cut panels to adjust them to doors and windows gross dimensions, before doors and windows installation. Cut panels flush to the gross opening.
- 2** Cut the air barrier membrane at an angle of 45° on minimum of 150 mm [6''] at the upper corners of the opening; in order to expose the insulation panel. Cut only into the membrane thickness. Do not cut the insulation.
- 3** Pull the air barrier strip between the two diagonal cuts to remove the air barrier from the insulating panel. Lift the membrane upwards. As necessary, temporarily secure with an adhesive tape in order to facilitate the flexible membrane installation.
- 4** Install a compatible self-adhesive flexible membrane⁺⁺ over the entire width of the sill.
- 5** Fold back the self-adhesive flexible membrane on the SR.Air™200 panel and along the jambs on 150 mm [6''] min.
- 6** Install a piece of flexible membrane to the bottom corners in order to limit corner air spaces and thus reducing unforeseen water infiltrations.
- 7** Install a compatible self-adhesive flexible membrane⁺⁺ along the opening jambs. Overlap every flexible membrane strips on 150 mm [6''] min.
- 8** Cut the flexible membrane as shown.
- 9** Install a compatible self-adhesive flexible membrane⁺⁺ on lintel.
- 10** Fold back the flexible membrane on the vertical part of the lintel on 150 mm [6''] min.
- 11** Fold back the flexible membrane under the lintel, over all lintel width.

JUNCTION DETAILS

SR.AIR[®]

© SR.AIR[™] | 2020-02

➤ OPENING [LIGHTWEIGHT CLADDING]

- 1** Fix a compatible drip cap with the cladding [optional] according to cladding manufacturer's instructions and according to plans and specifications.
- 2** Fold forward the 45° cut air barrier strip over the flexible membrane of the lintel.
- 3** Seal all joints with compatible sealing tape[†].
- 4** To ensure continuous air and weather tightness of the envelope, seal the empty space between gross opening and window/door framing with an elastomeric sealant or with low expansion foam filling^{†††}.

➤ OPENING [MASONRY]

- 5** Fix a metal corner as specified by product's manufacturer and according to plans and specifications.
- 6** Fix a metal flashing.
- 7** Extend flashing beyond the corner end.
- 8** Install vertically a compatible self-adhesive and flexible membrane^{††}, on lintel and over the flashing.
- 9** If U shaped flashing is used, cut a vertical slot in the flexible membrane to accommodate the vertical edge of the flashing.
- 10** Overlap the vertical flexible membrane on minimum of 75 mm [3"] on the adjacent surfaces, on top and sides.
- 11** Fold forward the 45° cut air barrier strip over the flexible membrane of the lintel.
- 12** Seal all joints with compatible sealing tape[†].
- 13** To ensure continuous air and weather tightness of the envelope, seal the empty space between gross opening and window/door framing with an elastomeric sealant or with low expansion foam filling^{†††}.

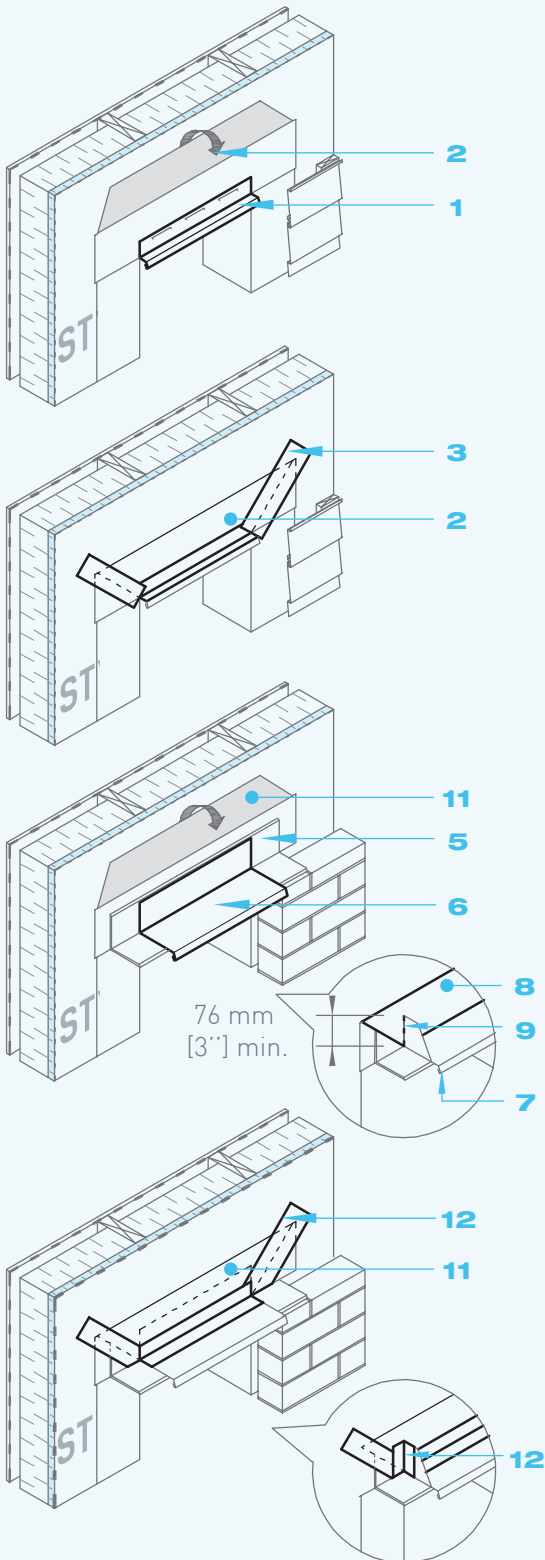

JUNCTION DETAILS

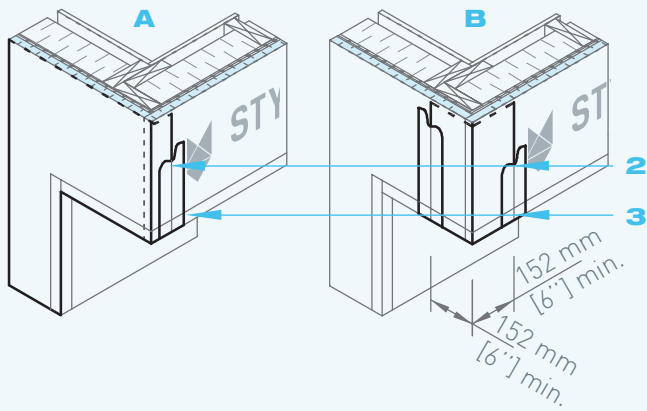

OBJECT WITHOUT FLANGE

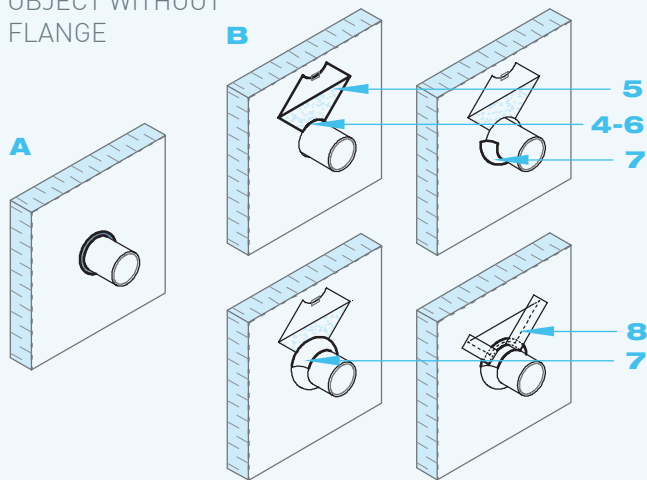

OBJECT WITH FLANGE

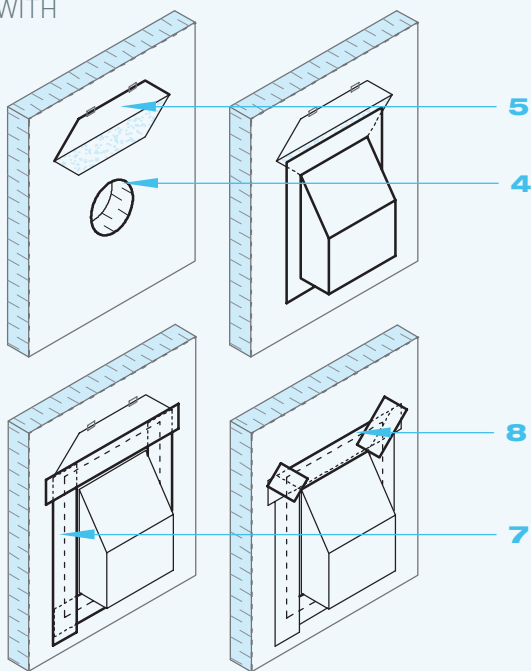

SR.AIR^{DS}™

© SR.AIR™ | 2020-02

➤ WALL CORNER OR CANTILEVERED WALL

1 Use one of the two following methods:

A Fold back the excess strip of the air barrier on the adjacent panel.

B Use a compatible air barrier strip[†] of a minimum width of 300 mm [12"] to join two panels.

2 Seal all horizontal and vertical joints between panels with compatible sealing tape[†].

3 Seal external corners by folding downwards the sealing tape, under the cantilevered section. Fold back the tape in order to cover the whole corner.

➤ PENETRATION [PIPE, DUCT, ETC.]

OBJECT WITHOUT FLANGE

Use one of the two following methods:

A Use a compatible scellant bead⁺⁺⁺ or,

B Use a compatible sealing tape[†] as described below.

OBJECT WITH FLANGE

4 Cut panels to adjust them to gross penetration dimensions.

5 Cut at an angle of 45° at the upper part of the opening. Temporarily secure with an adhesive tape.

6 Install the object.

7 Seal perimeter of the object with compatible sealing tape[†].

8 Fold forward the 45° cut section. Seal with compatible sealing tape[†].

GENERAL ADVICES

➤ RECOMMENDED PRODUCTS

† The sealing tape must be air and moisture proof, but permeable to water vapor. Tape must be compatible with the SR.Air™ air barrier membrane. For an optimum adhesion; use *Tuck®Tape* construction sheathing tape *Easy Tear* or equivalent.

†† The self-adhesive flexible membrane must be air and moisture proof, but permeable to water vapor. It must be installed according to the manufacturer's instructions. The *Blueskin® SA* or *WP* from *Henry Baker* and *Hi-tac* primer from *Henry Baker* are compatible with expanded polystyrene and air-barrier membrane. Validate the self-adhesive flexible membrane compatibility with other surfaces to be joined and manufacturer's restrictions.

††† Sealants must be compatible with expanded polystyrene. Use *ADFoam* from *ADFast* polyurethane insulating foam or equivalent. Especially validate the sealant compatibility with utilized self-adhesive flexible membrane.

‡ For junctions requiring air barrier strips, use any kind of air barriers strips, available on rolls in various widths.

➤ STORAGE AND COVERING

Store panels in a dry location, protected from the outside elements, ultraviolet rays, open flames or other sources of ignition. Stack panels on pallets of minimum 100 mm [4"] above the ground. If provided packaging has been damaged during shipping, cover panel with a weather and ultraviolet tarp. Panels must be dry and in good condition before installation.

Cover the panels within 60 days after installation with an exterior cladding protecting from ultraviolet rays.

➤ EXEMPTION FROM LIABILITY

The information herein is based on the present state of our best scientific and practical knowledge. They are provided to facilitate Styro Rail™ product's installation and may not apply to all situations. The user is responsible for checking the suitability of products for their intended use. Styro Rail™ installation guides are updated on a regular basis; it is the user's responsibility to obtain and to confirm the most recent version. Information contained in this data sheet may change without notice. The drawings and details herein have not been scaled up.



Expand your world

Styro Rail Inc. 65 Route 105, La Pêche, Québec J0X 3G0
T 1 819 643-4456 1 888 332-3456 F 819 459-1621

