



INSTALLATION GUIDE

The **SR.Drain™** panels manufactured by Styro Rail™ are composed of type 2 [200 series] or type 3 [300 to 600 series] expanded polystyrene [EPS] rigid insulation. They comprise of a smooth surface and a surface with diamond a shaped pattern allowing water to drain downwards.

➤ RECOMMENDED USE

Install **SR.Drain™** panels on the exterior surface of the foundation walls, the channeled surface on the interior side, towards the foundation wall, in order to obtain a continuous insulation of the wall and enhancing the effectiveness of a waterproofing system. The draining diamonds contribute to channeling sub-surface water away and preventing the built-up of hydrostatic pressure against the structure. The type 3 **SR.Drain™** panels are ideal for prolonged groundwater contact applications; with the lowest water absorption rate of the three available EPS types.

➤ PANEL COMPOSITION

A Type 2 or Type 3 Expanded Polystyrene Rigid Panel Insulation [EPS] manufactured by Styro Rail™

B Drainage diamonds

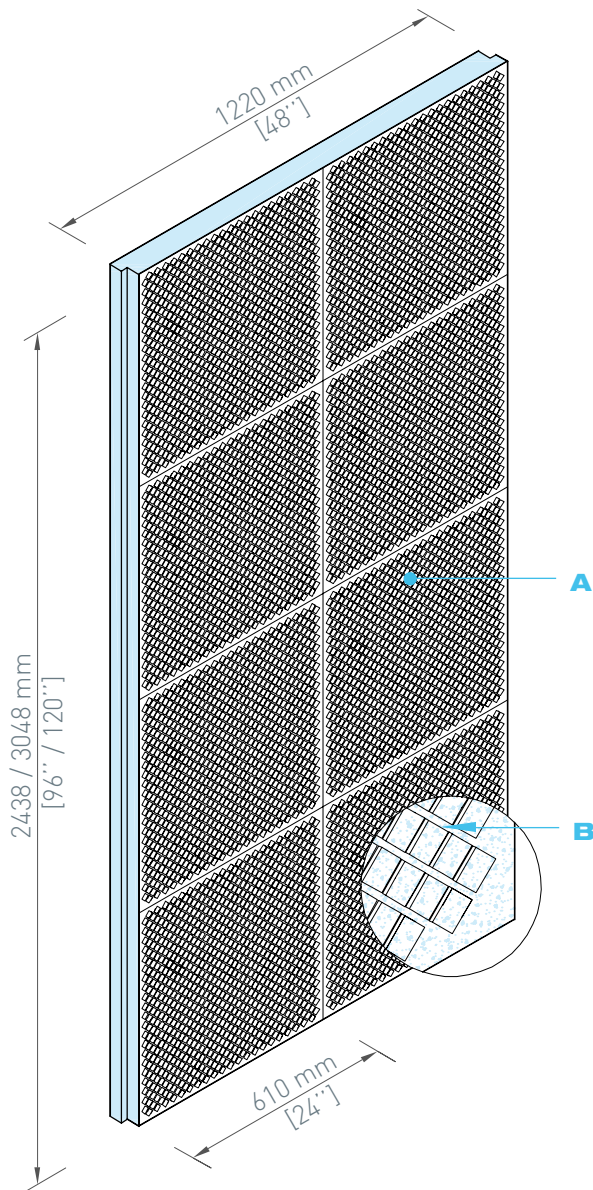

PANEL INSTALLATION

SR.DRAIN™

© SR.DRAIN™ | 2017-02

GENERAL INSTALLATION

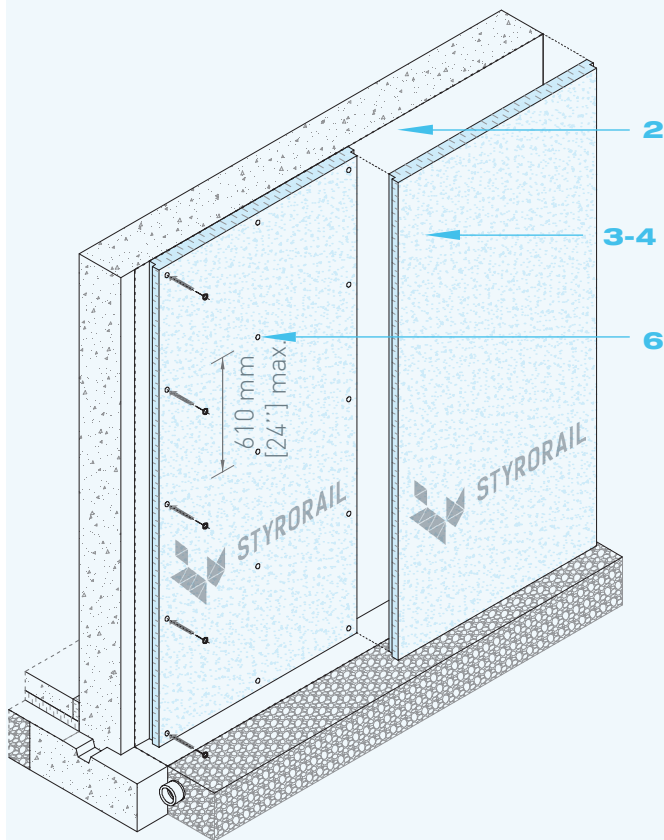

- 1 Using the flat surface of a hammer; scratched the surface of the concrete wall to remove concrete bumps.
- 2 Install a waterproofing membrane on the concrete wall. Install as specified by the manufacturer.
- 3 Install SR.Drain™ panels vertically on the full height of the wall, the drainage diamonds toward the foundation wall.
- 4 Install panels left to right. Install panels continuously and uniformly. Butt ends between panels.
- 5 Fix panels using corrosion-resistant screws or insulation nails^{††} ensuring a penetration in the concrete wall with a minimum of 38 mm [1-1/2'']. Use screws with plastic washers of minimum 25 mm [1''] in diameter.
- 6 Fix panels by allowing a spacing of maximum 610 mm [24''] between screws.
- 7 Fix the screws at approximately 51 mm [2''] from the edges.
- 8 As necessary, pre-drill the foundation wall with an impact drill.
- 9 Backfill the foundation.
- 10 Install an exterior finish coating on the exposed section of the insulating panels.
- 11 At inside and outside corners, cut off the ship lap to ensure a continuous joint between the panels.

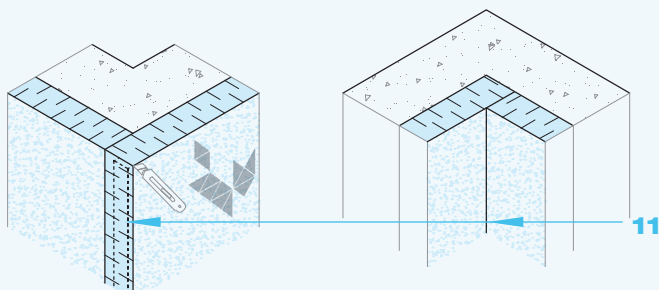
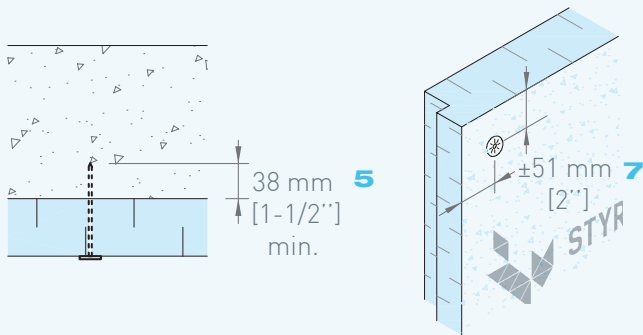

PANEL INSTALLATION

SR.DRAIN™

© SR.DRAIN™ | 2017-02

GENERAL FIXATION

- 1 For foundation backfilled at approximately 305 mm [12'], fix the first row of screws at approximately 51 mm [2'] of the edges.
- 2 Allow a spacing of maximum 610 mm [24'] between the fixations.
- 3 Install a few screws on the remaining surface of the panel to maintain in place until the backfill.
- 4 Backfill the foundation at approximately 305 mm [12']. The soil weight will maintain the panels in place.

EXTERIOR FINISH

- 5 Install a flashing on the foundation.
- 6 Exceed the flashing over the insulating panels and the exterior finish coating.
- 7 Install an exterior finish coating such as stucco.

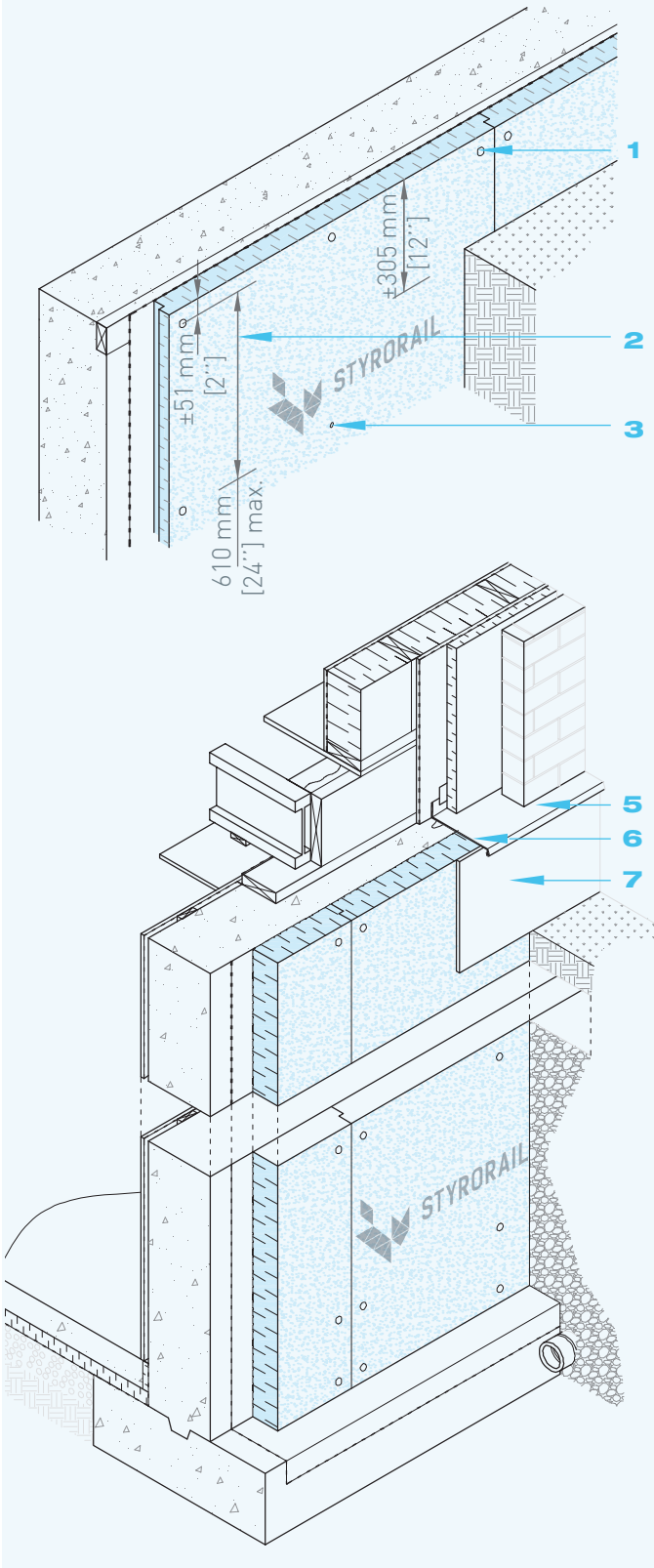

JUNCTIONS DETAILS

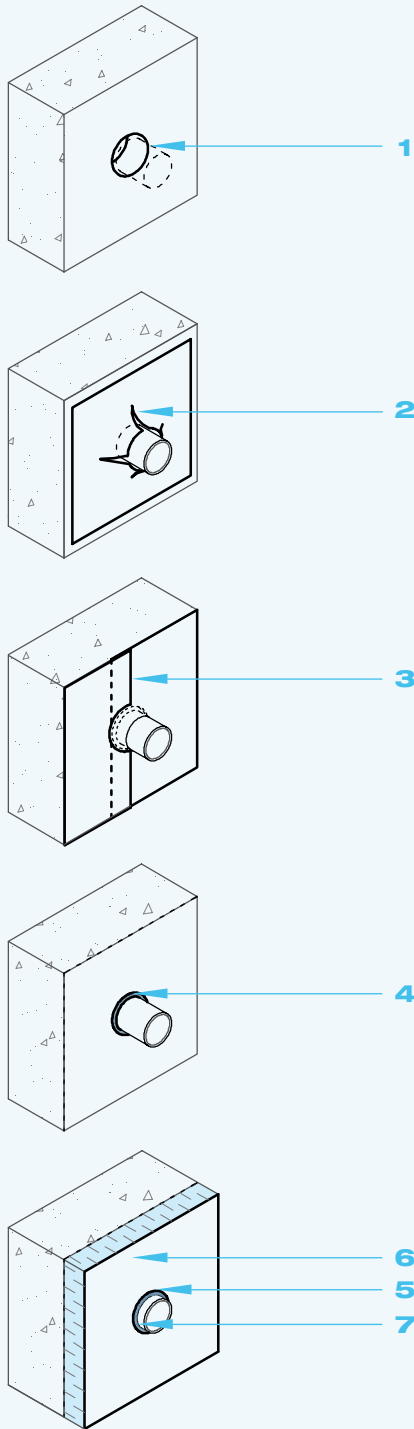

SR.DRAIN™

© SR.DRAIN™ | 2017-02

➤ PENETRATION [PIPE, DUCT, ETC.]

- 1** Drill a hole for the openings using a concrete drill and with an appropriate size bit. Install duct before the installation of the waterproof membrane.
- 2** If the membrane is in a roll format; cut a square shape piece of membrane with a cross shape slot. Insert the square shape piece on the duct.
- 3** Install the membrane on the concrete wall. Install as specified by the manufacturer.
- 4** If the membrane is a liquid type; seal around the duct using a compatible sealant bead as specified by the manufacturer.
- 5** Cut the insulating panels using a drill with an appropriate diameter bit or with a gypsum saw. Adjust the cut to gross openings of the pipes.
- 6** Install the insulating panels as per the installation method described in this guide.
- 7** Seal around the pipe using a compatible sprayed urethane bead[†].

GENERAL ADVICES

➤ RECOMMENDED PRODUCTS

† Sealants must be compatible with expanded polystyrene. Use *ADFoam* from *ADFast* polyurethane insulating foam or equivalent.

†† Use nails for insulation fixation *XI-FV* from *Hilti* or equivalent.

➤ STORAGE AND COVERING

Store panels in a dry location, protected from the outside elements, ultraviolet rays, open flames or other sources of ignition. Stack panels on pallets of minimum 100 mm [4"] above the ground. If provided packaging has been damaged during shipping, cover panels with a weather and ultraviolet tarp. Panels must be dry and in good condition before installation.

Cover the panels within 60 days after installation with an exterior cladding protecting from ultraviolet rays.

➤ EXEMPTION FROM LIABILITY

The information herein is based on the present state of our best scientific and practical knowledge. They are provided to facilitate Styro Rail™ product's installation and may not apply to all situations. The user is responsible for checking the suitability of products for their intended use. Styro Rail™ installation guides are updated on a regular basis; it is the user's responsibility to obtain and to confirm the most recent version. Information contained in this data sheet may change without notice. The drawings and details herein have not been scaled up.



Expand your world

Styro Rail Inc. 65 Route 105, La Pêche, Québec J0X 3G0
T 1 819 643-4456 1 888 332-3456 F 819 459-1621

