

CORNER REINFORCEMENT

ZIP-TIE THE INTERLOCKING NUBS TOGETHER TO REINFORCE THE CORNER. BOND THE CUT EDGES TOGETHER WITH FOAM2FOAM OR SIMILAR LOW EXPANDING FOAM ADHESIVE.

ADEQUATE BRACING AND STRAPPING IS REQUIRED FOR ALL FIELD FABRICATED CORNERS. LARGER BLOCK CORES REQUIRE ADDITIONAL BRACING AND STRAPPING ON OUTSIDE CORNER CUTS. CONTACT BUILDBLOCK TECHNICAL SUPPORT FOR MORE INFORMATION.

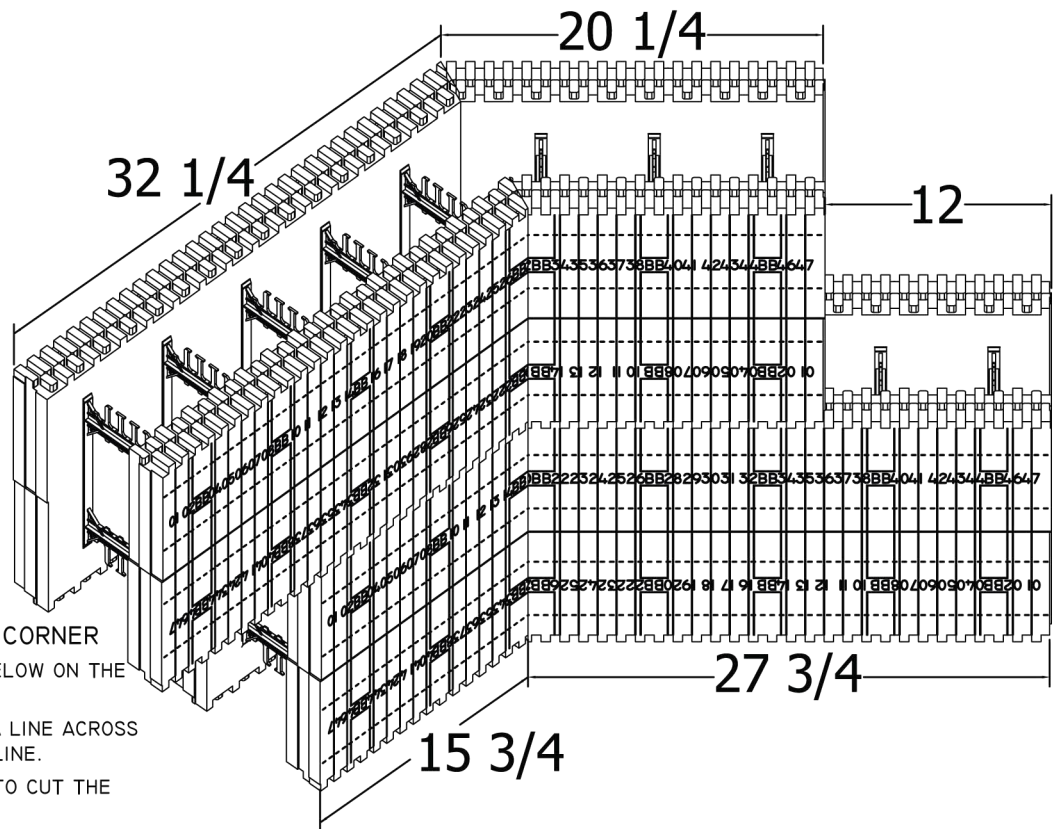

HOW TO FIELD FABRICATE A CORNER

1. MARK THE DIMENSIONS SHOWN BELOW ON THE BLOCK.
2. USING A STRAIGHT EDGE, DRAW A LINE ACROSS THE FORM TO SERVE AS A GUIDELINE.
3. USE A HOT KNIFE OR HAND SAW TO CUT THE FORM.
4. FLIP ONE OF THE HALVES AND ALIGN TO THE CUT EDGES TO MAKE THE MITERED CORNER.
5. FOAM GLUE THE EDGES, ZIP-TIE THE INTERLOCKING NUBS, AND ADD STRAPPING AND BRACING AS REQUIRED.

NOTE:

FIELD CUT CORNERS CAN BE EASILY MADE USING THESE DIMENSIONS. THE CUTS ARE DESIGNED TO ALLOW A SUFFICIENT RUNNING BOND FOR THE FORMS.

THESE DIMENSIONS DO NOT MATCH FACTORY CORNERS. CUTS SHOULD BE MADE WITH THE MOST ACCURATE SAW AVAILABLE. FIELD MITERS SHOULD BE REINFORCED WITH WOOD OR METAL STRAPPING AND BRACED ADEQUATELY. SEE THE BUILDBLOCK INSTALLATION & TECHNICAL MANUAL FOR MORE DETAIL ON STRAPPING AND BRACING.

 <p>SYSTÈME DE COFFRAGE ISOLANT PRODUIT PAR STYRORAIL INSULATING CONCRETE FORMS MANUFACTURED BY STYRORAIL 65, ROUTE 105, LA PÊCHE, QUEBEC, J0X 3G0 OFFICE: 819-643-4456 TOLL FREE: 888-332-3456 STYRORAIL.CA</p>	BB-645/BL-645 45° FIELD FABRICATED CORNER				
	DATE/REV	8/2015	SCALE	NTS	DETAIL SHEET
	NOTES				<h1>59D</h1>
	CONSTRUCTION SHALL BE IN ACCORDANCE WITH ALL APPLICABLE LOCAL AND NATIONAL CODES. ALL DRAWINGS ARE SUBJECT TO CHANGE WITHOUT NOTICE.				